



WESTIN[®]

PUBLIC SAFETY DIVISION
PRODUCT CATALOG
PROTECTING THOSE WHO PROTECT US





TABLE OF CONTENTS

DEFENDER FRONT PARTITION	4
DEFENDER REAR PARTITION	6
DEFENDER ELECTRONICS PANEL.....	8
DEFENDER PRISONER SEAT	10
ABS DOOR PANELS	12
DEFENDER SIDE WINDOW GUARDS	14
PUSH BUMPER ELITE XD.....	16
PUSH BUMPER ELITE	18
LIGHT CHANNEL OPTIONS	20
PIT BAR ELITE	22
ELITE WING WRAPS.....	24
HDX BANDIT FRONT AND REAR BUMPERS	26
HDX WINCH MOUNT GRILLE GUARD	28
WINCHES	30
LED LIGHTING	34
HLR TRUCK RACK.....	36
TESTIMONIALS	38
PHOTO GALLERY	39



KODAK SAFETY FILM

TS





FRONT PARTITION

PATENT PENDING

FASTEST INSTALL IN THE INDUSTRY

AIRBAG TESTED AND COMPLIANT

SLIDING POLYCARBONATE CENTER WINDOW

10-GAUGE UPPER MOUNTING BRACKETS

TAMPER PROOF HARDWARE

ANTI-GLARE, SCRATCH RESISTANT POLYCARBONATE WINDOW

18-GAUGE, 1.5" TUBULAR FRAME

20% MORE VIEWING AREA THAN THE COMPETITION!

16 GAUGE POWDER COATED STEEL

SPECIFICATIONS:

FINISH: BLACK POWDER COAT
 MATERIAL: COLD ROLLED STEEL
 WARRANTY: 3 YEAR

RECESSED AND FLAT PANELS INCLUDED

RECESSED FOOTWELLS INCLUDED

RECESSED DESIGN ALLOWS FOR MAXIMUM DRIVER COMFORT

- 18 GAUGE 1.5" TUBULAR FRAME
- 16 GAUGE POWDER COATED STEEL
- RECESSED FOOT WELLS INCLUDED
- TAMPER PROOF HARDWARE USED ON ALL EXPOSED HARDWARE IN PRISONER AREA
- ANTI-GLARE/SCRATCH RESISTANT WINDOWS

- 10 GAUGE UPPER MOUNTING BRACKETS
- RECESSED AND FLAT PANELS INCLUDED
- QUICK AND EASY INSTALL - NO DRILLING OR CUTTING REQUIRED
- PATENT PENDING
- NO DRILLING REQUIRED

#WESTINPUBLICSAFETY

4

PRODUCT CATALOG

START	END	MAKE	MODEL	PART NO.
2015	2020	CHEVY	TAHOE PPV	35-10025
2021	2021	CHEVY	TAHOE PPV	35-10065
2015	2021	DODGE	CHARGER PURSUIT	35-10015
2011	2019	FORD	POLICE INTERCEPTOR UTILITY	35-20005
2018	2020	FORD	F-150 RESPONDER	35-10035
2020	2021	FORD	POLICE INTERCEPTOR UTILITY	35-20045



WESTIN PUBLIC SAFETY'S DEFENDER FRONT PARTITION UNIQUE DESIGN ALLOWS 20% MORE VIEWING AREA THAN THE COMPETITION AND OFFERS THE FASTEST INSTALL IN THE INDUSTRY. THE OVERALL RECESSED DESIGN ALLOWS FOR MAXIMUM DRIVER COMFORT AND THE 16 GAUGE POWDER COATED STEEL WITH 18 GAUGE 1.5" TUBULAR FRAME MAKES SAFETY THE HIGHEST PRIORITY. IT ALSO FEATURES RECESSED FOOT WELLS, ANTI-GLARE/ SCRATCH RESISTANT WINDOWS AND 10 GAUGE UPPER MOUNTING BRACKETS. AVAILABLE IN BLACK POWDER COAT AND BACKED BY A 3 YEAR WARRANTY.

CALL 800.345.8476 OR VISIT  WESTINPUBLICSAFETY.COM

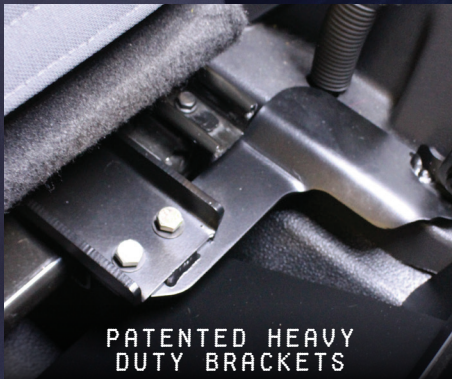

PATENTED HEAVY DUTY BRACKETS



RECESSED AND FLAT PANEL INCLUDED



RECESSED FOOTWELLS INCLUDED



REAR PARTITION

PATENT PENDING

WORKS WITH OR WITHOUT OPTIONAL ELECTRONICS PANEL

3" X 3/8" PUNCH PLATE OPENING DESIGNED FOR MAXIMUM VISIBILITY

STURDY NO RATTLE, NO SQUEAK DESIGN

CONFORMS TO HEADLINER FOR MINIMAL GAP

14-GAUGE POWDER COATED STEEL

GUSSETED FOR ADDITIONAL RIGIDITY AND STRENGTH

HEAVY DUTY SUPPORT BRACKETS

MOUNTS TO FACTORY BOLTS, NO DRILLING OR CUTTING REQUIRED ON MOST APPLICATIONS

#WESTINPUBLICSAFETY



PRODUCT CATALOG

SPECIFICATIONS:

- FINISH: BLACK POWDER COAT
- MATERIAL: STEEL
- WARRANTY: 3 YEAR



- PUNCH PLATE DESIGNED FOR MAXIMUM VISIBILITY
- STURDY NO RATTLE, NO SQUEAK DESIGN
- CONFORMS TO HEADLINER FOR MINIMAL GAP

- GUSSETED FOR ADDITIONAL RIGIDITY AND STRENGTH
- MOUNTS TO FACTORY BOLTS, NO DRILLING OR CUTTING REQUIRED ON MOST APPLICATIONS
- POLY WINDOW AVAILABLE

START	END	MAKE	MODEL	REAR PARTITION	REAR PARTITION POLY WINDOW	POLY REAR PARTITION
2015	2020	CHEVY	TAHOE PPV	35-12025	35-120252	-
2021	2021	CHEVY	TAHOE PPV	35-12065	35-120652	-
2011	2019	FORD	POLICE INTERCEPTOR UTILITY	35-12005	35-120052	-
2020	2021	FORD	POLICE INTERCEPTOR UTILITY ¹	35-12045	35-120452	-
2020	2021	FORD	POLICE INTERCEPTOR UTILITY	-	-	35-220452

FOOTNOTES: 1. DRILLING REQUIRED



WESTIN PUBLIC SAFETY'S DEFENDER REAR PARTITION GUSSETTED DESIGN AND 14 GAUGE POWDER COATED STEEL MEANS RIGIDITY AND STRENGTH ARE NEVER COMPROMISED. FOR MOST APPLICATIONS NO DRILLING OR CUTTING IS REQUIRED AS IT MOUNTS DIRECTLY TO FACTORY BOLTS WITH HEAVY DUTY BRACKETS AND SUPPORT BRACKETS. THE 3" X 3/8" PUNCH PLATE IS DESIGNED FOR MAXIMUM VISIBILITY AND CONFORMS TO HEADLINER FOR MINIMAL GAP AND BETTER FIT. WORKS WITH OR WITHOUT OPTIONAL ELECTRONICS BOX AND/OR POLY WINDOW. AVAILABLE IN BLACK POWDER COAT AND BACKED BY A 3 YEAR WARRANTY.

CALL 800.345.8476 OR VISIT



WESTINPUBLICSAFETY.COM

GS

KODAK SAFETY FILM



ELECTRONICS PANEL

PATENT PENDING

OPTION FOR DEFENDER REAR PARTITION

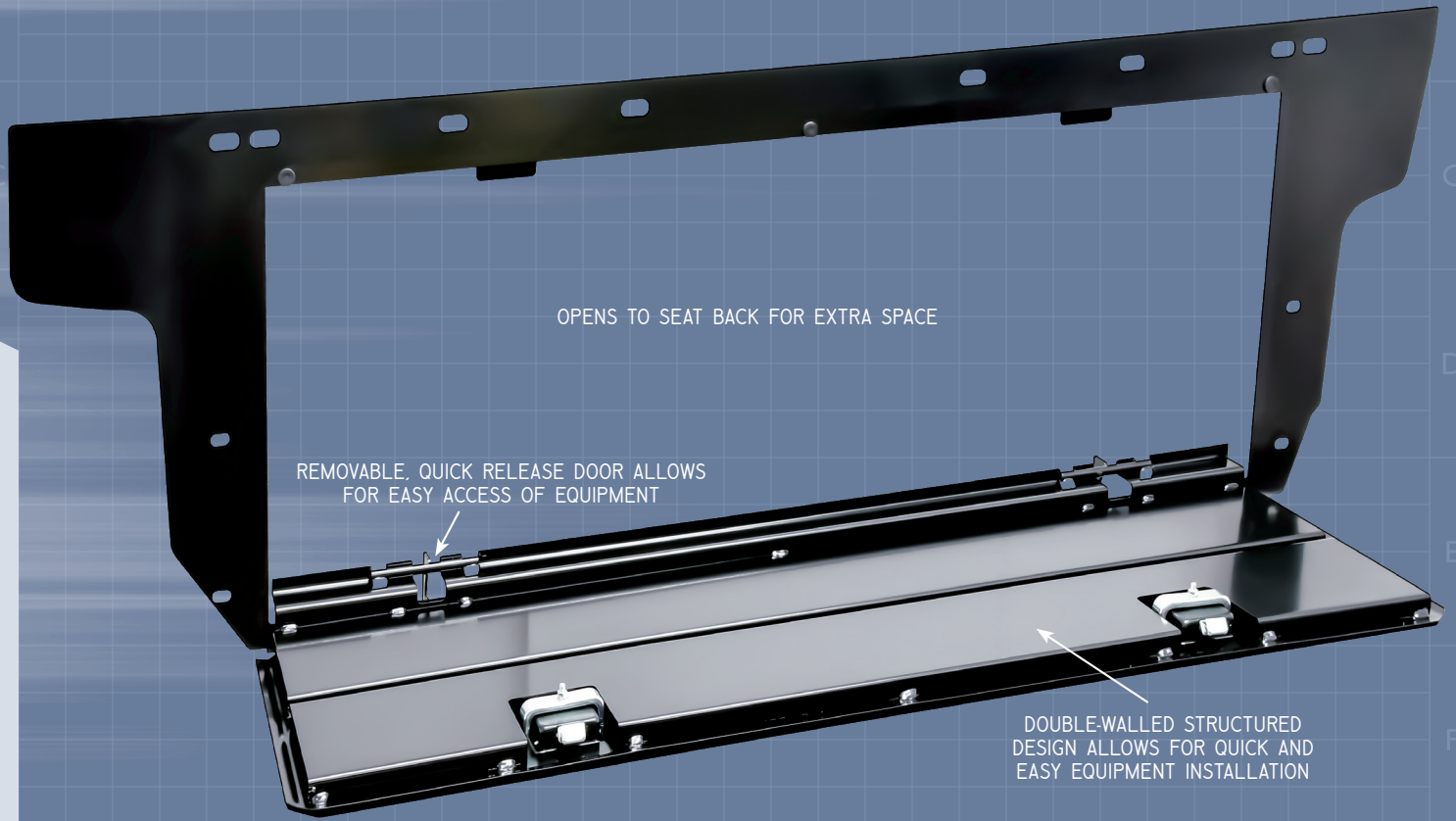

- REMOVABLE, SLIDE-OUT DOOR ALLOWS FOR EASY ACCESS OF EQUIPMENT
- OPENS TO SEAT BACK FOR EXTRA SPACE
- DOUBLE-WALLED STRUCTURED DESIGN ALLOWS FOR QUICK AND EASY EQUIPMENT INSTALLATION
- KEY-LATCHED FOR SECURITY
- EASY ACCESS TO FACTORY ELECTRICAL POWER AND GROUND CONNECTIONS ON PIU

SPECIFICATIONS:

FINISH: BLACK POWDER COAT
 MATERIAL: STEEL
 WARRANTY: 3 YEAR

#WESTINPUBLICSAFETY



PRODUCT CATALOG

START	END	MAKE	MODEL	ELECTRONICS PANEL
2015	2020	CHEVY	TAHOE PPV	35-120251
2021	2021	CHEVY	TAHOE PPV	35-120651
2011	2019	FORD	POLICE INTERCEPTOR UTILITY	35-120051
2020	2021	FORD	POLICE INTERCEPTOR UTILITY	35-120451

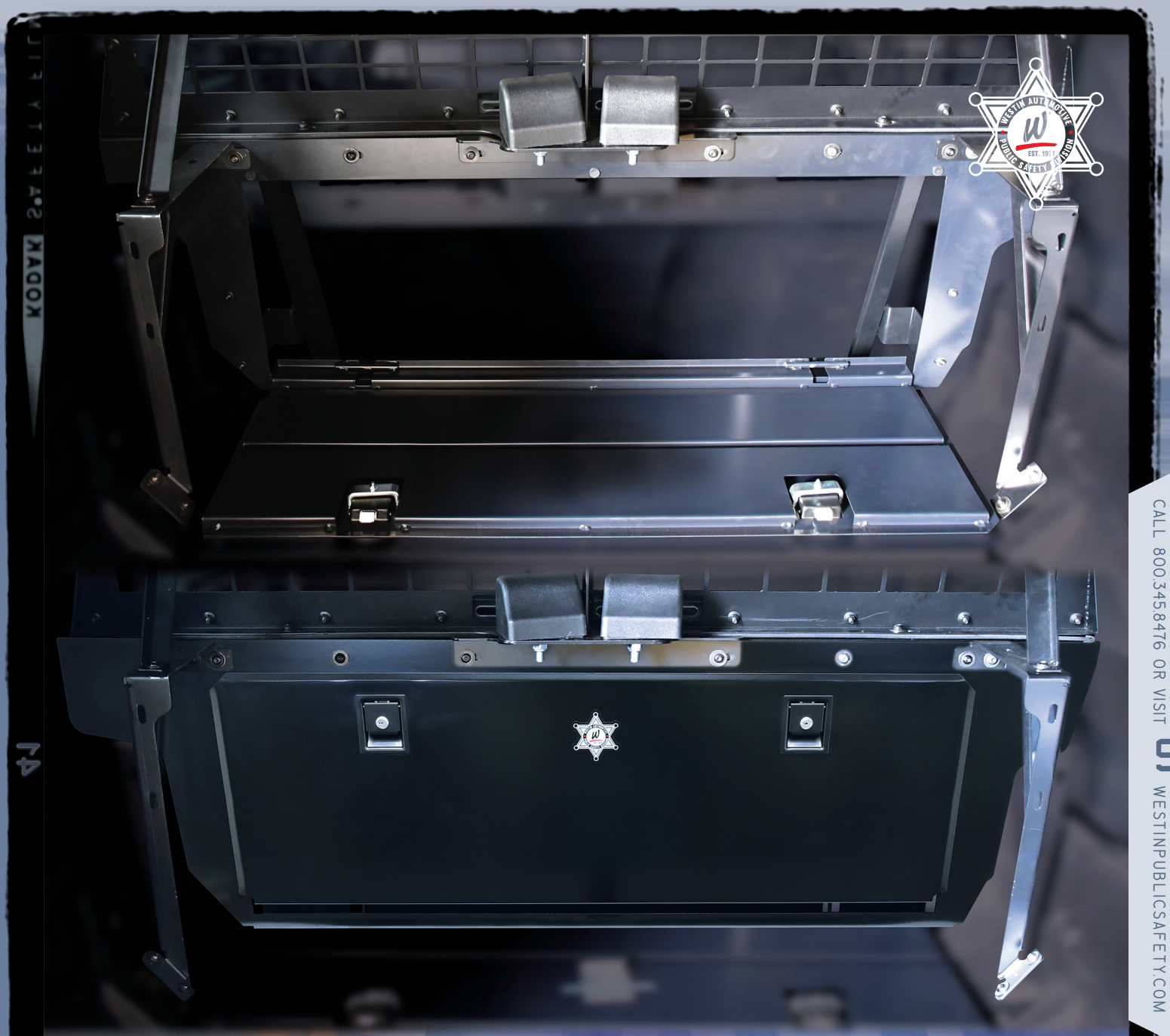

CALL 800.345.8476 OR VISIT  WESTINPUBLICSAFETY.COM

WESTIN PUBLIC SAFETY'S DEFENDER ELECTRONICS BOX IS THE PERFECT MATCH FOR YOUR DEFENDER REAR PARTITION. REMOVABLE, QUICK RELEASE DOOR ALLOWS FOR EASY ACCESS OF EQUIPMENT AND THE DOUBLE-WALLED DESIGN ALLOWS FOR AN EASY INSTALLATION. OPENS TO SEAT BACK FOR EXTRA SPACE AND FEATURES VENTS FOR HEAT DISSIPATION AND A KEY-LATCH FOR SECURITY. AVAILABLE IN BLACK POWDER COAT AND BACKED BY A 3 YEAR WARRANTY.



DOUBLE-WALLED FOR EQUIPMENT MOUNTING



KEY-LATCHED FOR SECURITY



PRISONER SEAT

EASY INSTALLATION / INCLUDES READY BUCKLE SEAT BELT SYSTEM



SPECIFICATIONS:
FINISH: BLACK
MATERIAL: ABS
WARRANTY: LIMITED LIFETIME

- MADE FROM STRONG ABS MATERIAL
- EASY INSTALLATION
- QUICKER SUSPECT LOADING DUE TO INCREASED ROOM
- QUICKER, SAFER AND MORE THOROUGH BIOHAZARD CLEANUP

- FLAT, CREVICE-FREE SURFACE ELIMINATES NEED TO SEARCH FOR DANGEROUS CONTRABAND OR MISSING EVIDENCE
- FORMED TO FIT VEHICLE CONTOURS
- RESTRAINING CENTER PULL SEAT BELT INCORPORATED FOR OFFICER SAFETY

START	END	MAKE	MODEL	PRISONER SEAT
2015	2020	CHEVY	TAHOE PPV ¹	35-14025
2021	2021	CHEVY	TAHOE PPV ¹	35-14065
2015	2021	DODGE	CHARGER PURSUIT ¹	35-14015
2011	2019	FORD	POLICE INTERCEPTOR UTILITY ¹	35-14005
2018	2020	FORD	F-150 SSV/POLICE RESPONDER ¹	35-14035
2020	2021	FORD	POLICE INTERCEPTOR UTILITY ¹	35-14045

FOOTNOTES: 1. DRILLING REQUIRED

OUR DEFENDER PRISONER SEAT IS FORMED FROM STRONG ABS MATERIAL AND ENGINEERED TO FIT VEHICLE CONTOURS. INCREASED ROOM MAKES FOR QUICK SUSPECT LOADING AND CREVICE-FREE DESIGN PREVENTS CONCEALMENT OF CONTRABAND OR EVIDENCE. THE MATERIALS AND CONSTRUCTION ALLOW FOR EASY, SAFE AND THOROUGH BIOHAZARD CLEANUP. INCLUDED IS THE DEFENDER READY BUCKLE SEAT BELT SYSTEM.



CALL 800.345.8476 OR VISIT



WESTINPUBLICSAFETY.COM

KODAK SAFETY FILM

24

ABS DOOR COVER PANELS

CUSTOM FORM FITTED FOR EACH APPLICATION

MADE FROM DURABLE ABS MATERIAL

PROTECTION FOR DRIVER SIDE AND PASSENGER SIDE REAR DOORS

SOLD AS A PAIR

SPECIFICATIONS:

FINISH: BLACK

MATERIAL: ABS

WARRANTY: LIMITED LIFETIME

- DOOR COVER PROTECTION FOR REAR PASSENGER AND DRIVER SIDE DOORS
- EASILY INSTALLS OVER EXISTING OEM DOOR PANEL

- QUICK INSTALLATION*
- MADE FROM DURABLE ABS MATERIAL
- SOLD AS A PAIR

START	END	MAKE	MODEL	DOOR PANEL
2015	2020	CHEVY	TAHOE PPV ¹	35-15025
2021	2021	CHEVY	TAHOE PPV ¹	35-15065
2015	2021	DODGE	CHARGER PURSUIT ¹	35-15015
2011	2019	FORD	POLICE INTERCEPTOR UTILITY ¹	35-15005
2018	2020	FORD	F-150 SSV/POLICE RESPONDER ¹	35-15035
2020	2021	FORD	POLICE INTERCEPTOR UTILITY ¹	35-15045

FOOTNOTES: 1. DRILLING REQUIRED



THESE DOOR COVER PANELS OFFER THE BEST PROTECTION FOR DRIVER AND PASSENGER SIDE REAR DOORS. MADE FROM DURABLE ABS MATERIAL, THE DOOR COVER PANELS EASILY INSTALL OVER EXISTING OEM DOOR PANELS AND ARE SOLD IN SETS OF (2).



SIDE WINDOW GUARDS

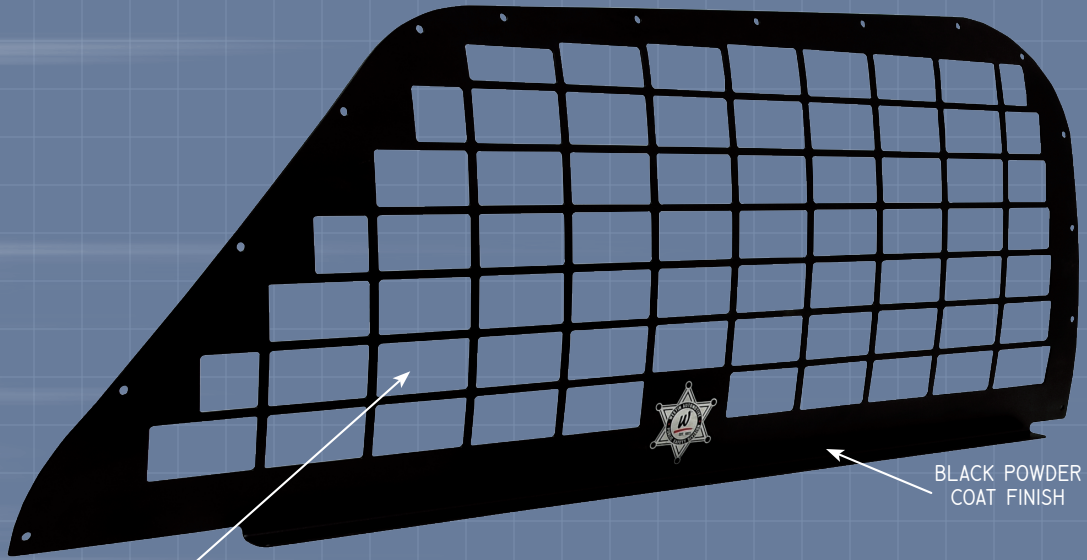

PUNCHED RECTANGULAR DESIGN PROVIDES MAXIMUM VISIBILITY AND FULL WINDOW PROTECTION

BLACK POWDER COAT FINISH

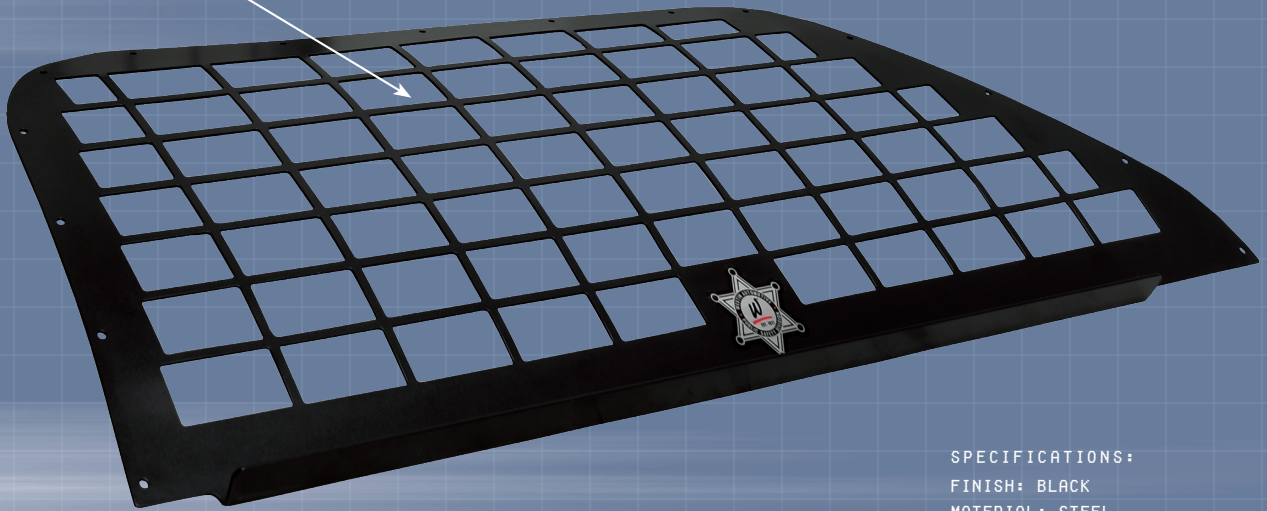

SPECIFICATIONS:
FINISH: BLACK
MATERIAL: STEEL
WARRANTY: 3 YEAR

- CREATES A SECURE, CONFINED PASSENGER COMPARTMENT
- BLACK POWDER COAT FINISH
- PUNCHED RECTANGULAR DESIGN PROVIDES MAXIMUM VISIBILITY AND FULL WINDOW PROTECTION
- DESIGNED FOR QUICK AND EASY INSTALLATION*

START	END	MAKE	MODEL	SIDE WINDOW GUARD	REAR WINDOW GUARD
2021	2021	CHEVY	TAHOE PPV ¹	35-16065	-
2018	2020	FORD	F-150 SSV/RESPONDER ¹	35-16035	35-12035
2020	2021	FORD	POLICE INTERCEPTOR UTILITY ¹	35-16045	-
2011	2019	FORD	POLICE INTERCEPTOR UTILITY ¹	35-16005	-
2015	2021	DODGE	CHARGER PURSUIT ¹	35-16015	-

FOOTNOTES: 1. DRILLING REQUIRED



KODAK SAFETY FILM

CALL 800.345.8476 OR VISIT  WESTINPUBLICSAFETY.COM

DEFENDER SIDE WINDOW GUARDS PUNCHED RECTANGLE DESIGN BRING MAXIMUM VISIBILITY AND FULL WINDOW PROTECTION WITH QUICK AND EASY INSTALLATION. AVAILABLE IN BLACK POWDER COAT FINISH, THESE WINDOW GUARDS FORM A SECURE, CONFINED PASSENGER CHAMBER.



WESTIN
PUBLIC SAFETY DIVISION

XTREME DUTY

PUSH BUMPER ELITE XD

WITH OPTIONAL WING WRAPS, PIT BAR AND WINCH TRAY

#WESTINPUBLICSAFETY

16

PRODUCT CATALOG



SPECIFICATIONS:

- FINISH: E-COATED / BLACK POWDER COAT
- LIGHT CHANNEL: SOLD SEPARATELY
- MATERIAL: HRPO STEEL
- VISIBLE HARDWARE: BLACK PLATED STAINLESS STEEL
- WARRANTY: 3 YEAR



WINCH TRAY

FITS MOST MEDIUM FRAME 8,000-12,000 LBS WINCHES (UP TO 10-1/4" TALL)

MAX® TOW HOOK



PART NO. 46-3005
1 UNIT PER PACKAGE

START	END	MAKE	MODEL	ELITE XD*	PIT BAR**	WING WRAPS**	WINCH TRAY**	WIRE COVER
2015	2020	FORD	F-150 SSV/POLICE RESPONDER ^{3, 7, 8}	36-52065	N/A	36-52065W	46-23835	36-52065WC
2015	2017	FORD	EXPEDITION/SSV ¹	36-53865	N/A	36-53865W	46-23865	-
2019	2020	RAM	RAM SSV 1500 CLASSIC ^{4, 7, 8}	36-53545	N/A	36-53545W	46-23755	-
2013	2018	RAM	RAM SSV 1500 ^{4, 7, 8}	36-53545	N/A	36-53545W	46-23755	-
2019	2021	CHEVY	SILVERADO 1500 (EXCL. LD 2019) ^{1, 4, 5, 6}	36-53955	N/A	36-53955W	46-23955	-
2019	2019	CHEVY	SILVERADO LD ^{1, 2, 4}	36-53875	N/A	36-53875W	46-23875	-
2016	2018	CHEVY	SILVERADO 1500 ^{1, 2, 4}	36-53875	N/A	36-53875W	46-23875	-
2014	2015	CHEVY	SILVERADO 1500 ^{7, 9}	36-53685	N/A	36-53685W	46-23685	-
2015	2020	CHEVY	TAHOE PPV	36-53805	36-53805PB	36-53805W	46-23805	36-53805WC

*LIGHT CHANNEL REQUIRED. SOLD SEPARATELY. **PIT BAR ELITE, WING WRAPS AND WINCH TRAY SOLD SEPARATELY.

FOOTNOTES: 1. TRIMMING IS REQUIRED OF TOW HOOK PLASTIC POCKETS 2. TOW HOOKS CANNOT BE REUSED WITH WINCH TRAY APPLICATIONS 3. PIT BAR ONLY FITS 2018-2019 XL / RESPONDER 4. WILL INTERFERE WITH FRONT PARKING SENSORS 5. WILL INTERFERE WITH FUNCTION OF FRONT CAMERA IF EQUIPPED 6. WILL INTERFERE WITH BLOCK HEATER PLUG 7. WILL INTERFERE WITH "ADAPTIVE CRUISE CONTROL", OR FORWARD COLLISION WARNING SYSTEMS THAT FEATURE GRILLE MOUNTED LASER CONTROL SENSORS IF EQUIPPED. 8. REMOVAL OF TOW HOOKS REQUIRED FOR INSTALLATION IF EQUIPPED. 9. TRIMMING OF AIR DAM / LOWER BUMPER VALANCE REQUIRED.



THE PUSH BUMPER ELITE XD IS MADE OF HEAVY DUTY 4 GAUGE HRPO STEEL UPRIGHTS TO SAFELY PUSH ANOTHER VEHICLE. IT FEATURES 2 3/4 INCH WIDE HEAVY-DUTY RUBBER STRIPS ON THE UPRIGHTS AND A REMOVABLE FULL PUNCH PLATE GRILLE. UPRIGHTS ARE PRE-DRILLED FOR THE ADDITION OF ELITE WING WRAPS AND PIT BAR ELITE. PRE-DRILLED HOLES PROVIDE SIDE-MOUNTING POINTS FOR POPULAR LED LIGHTS. THE PUSH BUMPER ELITE XD ALSO FEATURES AN EXTRA WIDE 4 5/8" STYLIZED AND PRE-DRILLED CENTER CROSS-PLATE WITH A SIGNIFICANT SURFACE AREA FOR TOP-MOUNTING OF LED LIGHTS OR SPEAKERS. ALL EXPOSED FASTENERS ARE BLACK PLATED STAINLESS FOR PROTECTION AGAINST RUST. THE PUSH BUMPER ELITE XD DESIGNS ARE VEHICLE SPECIFIC FOR A CLEAN FINISHED LOOK.

2015-20 FORD F150



PUSH BUMPER PART NO. 36-52065
WING WRAPS PART NO. 36-52065W

2019 CHEVY SILVERADO LD



PUSH BUMPER PART NO. 36-53875
WING WRAPS PART NO. 36-53875W

2015-20 CHEVY TAHOE



PUSH BUMPER PART NO. 36-53805
WING WRAPS PART NO. 36-53805W

2013-18 RAM



PUSH BUMPER PART NO. 36-53545
WING WRAPS PART NO. 36-53545W

CALL 800.345.8476 OR VISIT



WESTINPUBLICSAFETY.COM



WESTIN
PUBLIC SAFETY DIVISION

PUSH BUMPER ELITE

BEST IN STRENGTH, DURABILITY AND PROTECTION

PRODUCT CATALOG #WESTINPUBLICSAFETY

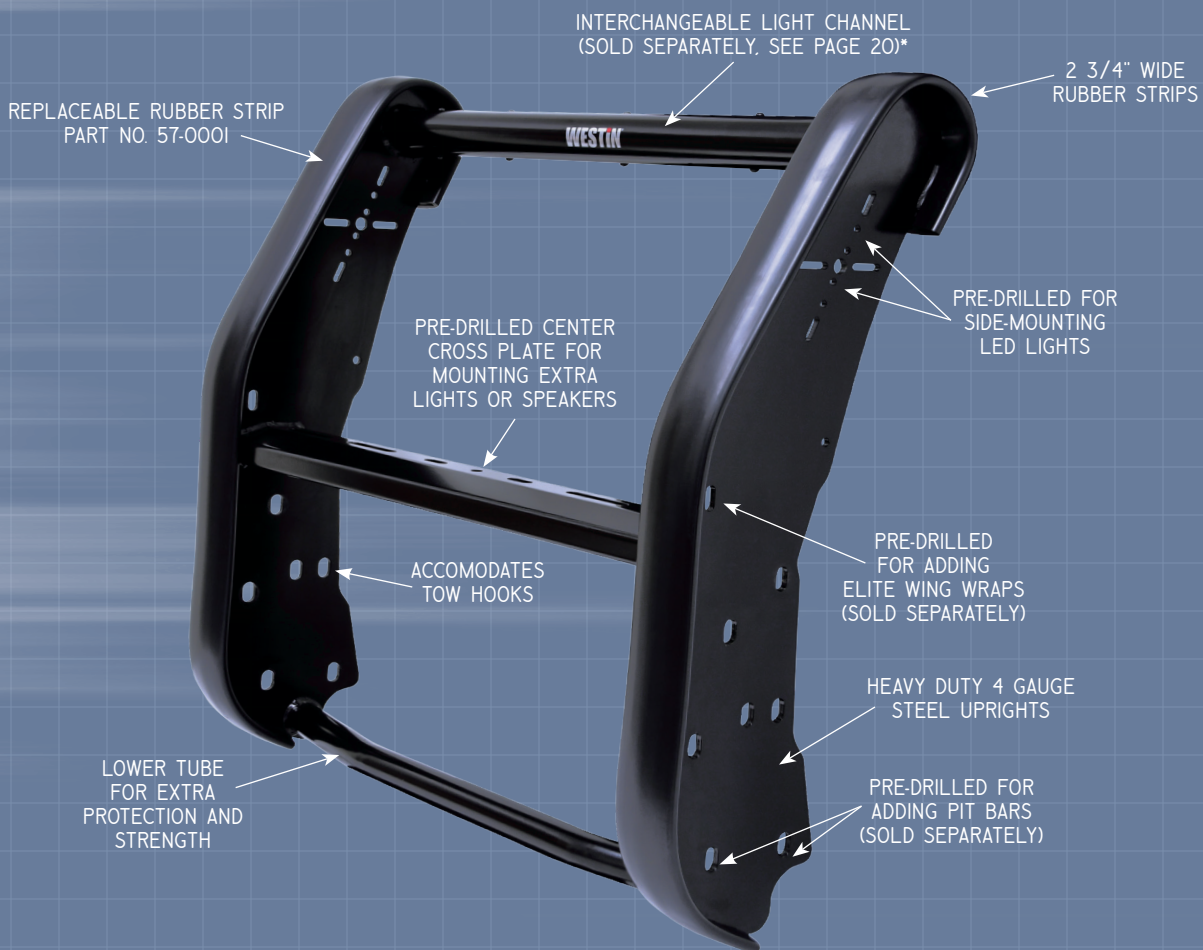

ACCOMODATES TOW HOOKS



OPTIONAL ELITE WIRE COVER SET



(SOLD SEPARATELY)

SPECIFICATIONS:
 FINISH: E-COATED / BLACK POWDER COAT
 LIGHT CHANNEL: SOLD SEPARATELY
 MATERIAL: HRPO STEEL
 VISIBLE HARDWARE: BLACK PLATED STAINLESS STEEL
 WARRANTY: 3 YEAR

START	END	MAKE	MODEL	PUSH BUMPER ELITE*	PIT BAR ELITE*	WING WRAP ELITE*	WIRE COVER
2020	2021	FORD	POLICE INTERCEPTOR UTILITY ²	36-2125	36-2125PB	36-2125W	36-2125WC
2016	2019	FORD	POLICE INTERCEPTOR UTILITY ²	36-2055	36-2055PB	36-2055W	36-2005WC
2012	2015	FORD	POLICE INTERCEPTOR UTILITY ²	36-2005	36-2005PB	36-2005W	36-2005WC
2013	2019	FORD	POLICE INTERCEPTOR SEDAN ^{1, 2}	36-2015	36-2015PB	36-2015W	-
2011	2021	DODGE	CHARGER PURSUIT ²	36-2035	36-2035PB	36-2035W	36-2035WC
2021	2021	CHEVY	TAHOE PPV	36-4045	36-4045PB	36-4045W	36-4045WC

*LIGHT CHANNEL REQUIRED. SOLD SEPARATELY.
 1. DRILLING REQUIRED FOR ECOBOOST MODEL 2. MINOR GRILLE TRIMMING REQUIRED



WESTIN'S PUBLIC SAFETY PUSH BUMPER ELITE IS MADE OF HEAVY DUTY HRPO STEEL WITH 4 GAUGE UPRIGHTS FEATURING 2-3/4" WIDE RUBBER STRIPS. THE PUSH BUMPER ELITE IS DESIGNED WITH MAXIMUM SAFETY FEATURES AND OPTIONS IN MIND. IT OFFERS CUSTOMIZATION FOR YOUR AGENCY'S SPECIFIC NEEDS AND PROVIDES THE BEST IN STRENGTH, DURABILITY, AND PROTECTION. CHOOSE A LIGHT CHANNEL TO COMPLETE YOUR PUSH BUMPER ELITE FRONT-END PROTECTION UNIT, AVAILABLE IN SOLID (NO LIGHT OPENINGS), 2, 3 OR 4 LIGHT OPTIONS.

2019 FORD INTERCEPTOR UTILITY



2020 FORD INTERCEPTOR UTILITY



2020 DODGE CHARGER



CALL 800.345.8476 OR VISIT  WESTINPUBLICSAFETY.COM

KODAK SAFETY FILM

72



WESTIN
PUBLIC SAFETY DIVISION

LIGHT CHANNEL OPTIONS

DESIGNED FOR MOST POPULAR PUBLIC SAFETY LIGHTS
SOLID, 2, 3, OR 4 LIGHT / LIGHTS NOT INCLUDED

SOLID

NO LIGHT OPENINGS



2 LIGHT

CHANNEL OPTION

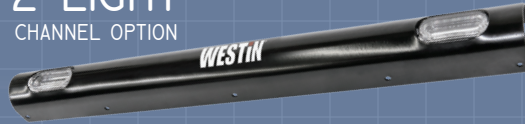

3 LIGHT

CHANNEL OPTION



4 LIGHT

CHANNEL OPTION

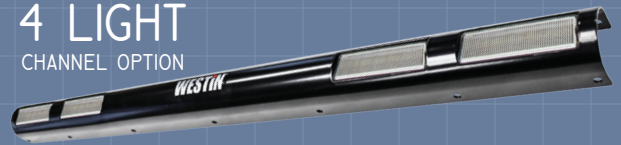

SOLID: NO LIGHT OPENINGS

WHELEN: ION-SERIES

CODE 3: CHASE

FEDERAL SIGNAL: IPX6-IMPAXX



PUSH BUMPER ELITE

STRT	END	MAKE	MODEL	PUSH BUMPER ELITE	NO LGT	SOUND OFF SIGNAL (NFORCE SURFACE MOUNT)		SOUND OFF (POWER)		CODE 3 (T-REX)		CODE 3 (XT4)		CODE 3 (CHASE)		CODE 3 (MR6)		FEDERAL SIGNAL (IMPAXX)		FEDERAL SIGNAL (MICRO PULSE6)		WHELEN (ION-SERIES)		
						SLD	2 LGT	4 LGT	2 LGT	4 LGT	2 LTS	4 LTS	2 LGT	4 LGT	2 LTS	3 LTS	4 LTS	2 LTS	4 LTS	2 LGT	4 LGT	2 LGT	4 LGT	2 LGT
2021	2021	CHEVY	TAHOE PPV	36-4045	36-6005	36-6005S2	36-6005S4	36-6005SMP2	36-6005SMP4	36-6005C2	36-6005C4	36-6005C2XT4	36-6005C4XT4	36-6005C2CH	36-6005C8CH	36-6005SMP4	36-6005SMP2	36-6005SMP4	36-6005F2	36-6005F4	36-6005F2MP	36-6005F4MP	36-6005W2	36-6005W4
2016	2019	FORD	POLICE INTERCEPTOR UTILITY	36-2055																				
2012	2015	FORD	POLICE INTERCEPTOR UTILITY	36-2005																				
2013	2019	FORD	POLICE INTERCEPTOR SEDAN	36-2015																				
2020	2021	FORD	POLICE INTERCEPTOR UTILITY	36-2125																				
2011	2020	DODGE	CHARGER PURSUIT	36-2035																				
2012	2017	CHEVY	CAPRICE PPV	36-2045																				

PUSH BUMPER ELITE XD

STRT	END	MAKE	MODEL	PUSH BUMPER ELITE XD	NO LGT	SOUND OFF SIGNAL (NFORCE)		SOUND OFF (POWER)		CODE 3 (T-REX)		CODE 3 (XT4)		CODE 3 (CHASE)		CODE 3 (MR6)		FEDERAL SIGNAL (IMPAXX)		FEDERAL SIGNAL (MICRO PULSE6)		WHELEN (ION-SERIES)	
						SLD	2 LGT	4 LGT	-	-	2 LGT	4 LGT	2 LGT	4 LGT	2 LGT	4 LGT	2 LGT	4 LGT	2 LGT	4 LGT	2 LGT	4 LGT	2 LGT
2015	2020	FORD	F-150 SSV/POLICE RESPONDER	36-52065	36-6015	36-6015S2	36-6015S4	36-6015SMP2	36-6015SMP4	36-6015C2	36-6015C4	36-6015C2XT4	36-6015C4XT4	36-6015C2CH	36-6015C4CH	36-6015SMP2	36-6015SMP4	36-6015F2	36-6015F4	36-6015F2MP	36-6015F4MP	36-6015W2	36-6015W4
2015	2017	FORD	EXPEDITION/SSV	36-53065																			
2019	2020	RAM	RAM SSV 1500 CLASSIC	36-53545																			
2013	2018	RAM	RAM SSV 1500	36-53545																			
2019	2019	CHEVY	SILVERADO LD	36-53075																			
2016	2018	CHEVY	SILVERADO 1500	36-53075																			
2014	2015	CHEVY	SILVERADO 1500	36-53685																			
2019	2021	CHEVY	SILVERADO 1500 (EXCL.LD 2019) 4-5	36-53955																			
2015	2020	CHEVY	TAHOE PPV	36-53005																			



WESTIN OFFERS LIGHT CHANNEL OPTIONS IN SOLID (NO LIGHT OPENINGS) AS WELL AS 2, 3 OR 4 LIGHT CONFIGURATIONS. THEY ARE DESIGNED FOR MOST POPULAR PUBLIC SAFETY LIGHTS: SOUNDOFF SIGNAL (NFORCE SURFACE MOUNT), CODE 3 (CHASE AND MR6), FEDERAL SIGNAL (IPX6-IMPAXX AND MICRO PULSE6), AND WHELEN (ION-SERIES). LIGHT CHANNELS INCLUDE LIGHT SPECIFIC BRACKETS AND HARDWARE. ONE OR MORE OF THESE LIGHT CHANNEL OPTIONS ARE SURE TO SERVE YOUR AGENCY'S PUBLIC SAFETY LIGHTING REQUIREMENT.

2020 FORD INTERCEPTOR UTILITY



2020 DODGE CHARGER



2020 CHEVY TAHOE



CALL 800.345.8476 OR VISIT  WESTINPUBLICSAFETY.COM



WESTIN
PUBLIC SAFETY DIVISION

PIT BAR ELITE

THE UNIQUE PATENTED DOUBLE BAR DESIGN
WITH OPTIONAL WING WRAPS AND PIT BAR

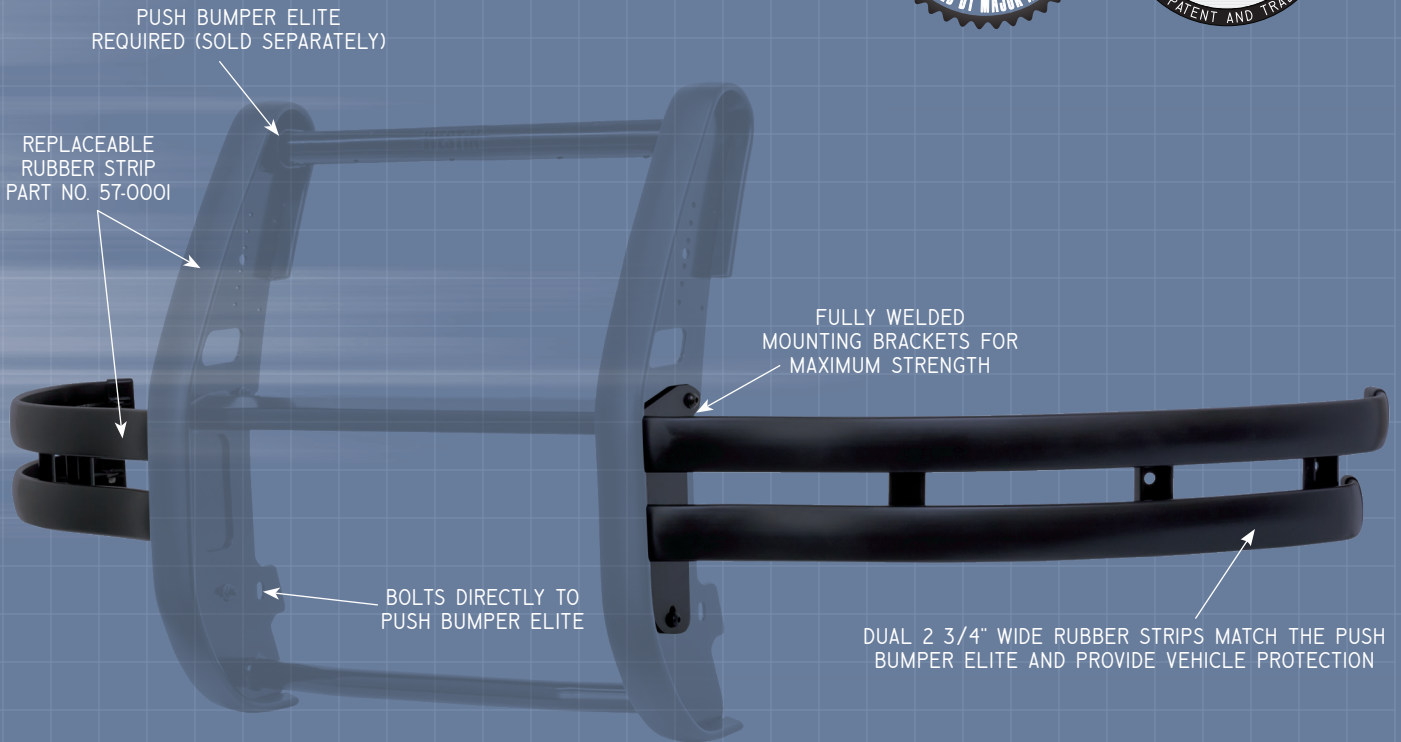

SPECIFICATIONS:
 MATERIAL: 7 GAUGE HRPO STEEL
 VISIBLE HARDWARE: BLACK PLATED STAINLESS STEEL
 WARRANTY: 3 YEAR

PATENT NUMBER # D755,094S

START	END	MAKE	MODEL	PUSH BUMPER ELITE	PIT BAR ELITE*
2021	2021	CHEVY	TAHOE PPV ¹	36-4045	36-4045PB
2020	2021	FORD	POLICE INTERCEPTOR UTILITY ¹	36-2125	36-2125PB
2016	2019	FORD	POLICE INTERCEPTOR UTILITY ^{1, 2}	36-2055	36-2055PB
2012	2015	FORD	POLICE INTERCEPTOR UTILITY ^{1, 3}	36-2005	36-2005PB
2013	2019	FORD	POLICE INTERCEPTOR SEDAN ^{1, 3}	36-2015	36-2015PB
2011	2021	DODGE	CHARGER PURSUIT ^{1, 3}	36-2035	36-2035PB

*PUSH BUMPER ELITE REQUIRED. SOLD SEPARATELY.

START	END	MAKE	MODEL	PUSH BUMPER ELITEXD	PIT BAR ELITEXD**
2018	2020	FORD	F-150 SSV/POLICE RESPONDER ¹	36-52065	36-52065PB
2015	2020	CHEVY	TAHOE PPV ^{1, 3}	36-53805	36-53805PB

**PUSH BUMPER ELITEXD REQUIRED. SOLD SEPARATELY.

FOOTNOTES: 1. REQUIRES BUMPER AND OR VALANCE DRILLING 2. DOES NOT WORK W /OE FOG LIGHTS 3. DOES NOT INCLUDE PIT BAR LIGHT BRACKET



OPTIONAL LIGHT MOUNT

WESTIN'S PIT BAR ELITE HAS BEEN RIGOROUSLY PIT TESTED AND APPROVED BY MAJOR PUBLIC SAFETY AGENCIES. THE PIT BAR ELITE IS MADE OF HEAVY DUTY 7 GAUGE HRPO STEEL HORIZONTAL BARS AND FEATURES TWO 2-3/4" WIDE RUBBER STRIPS WITH PLASTIC END CAPS FOR A CLEAN FINISHED LOOK. IT ALSO FEATURES HEAVY DUTY HRPO STEEL REINFORCING BRACKETS FOR MAXIMUM STRENGTH. WESTIN'S PUBLIC SAFETY PIT BAR ELITE IS DESIGNED TO BOLT DIRECTLY TO A WESTIN PUSH BUMPER ELITE OR ELITEXD AT THE UPPER BUMPER LEVEL FOR THE BEST PIT MANEUVER POSSIBLE.

PLASTIC END CAPS FOR FINISHED LOOK



HEAVY DUTY REINFORCING BRACKETS



BOLTS DIRECTLY TO PUSH BUMPER



SPECIAL CURVED DESIGN PREVENTS PUSH BUMPER FROM BEING HUNG UP





WESTIN
PUBLIC SAFETY DIVISION

ELITE WING WRAPS

A COMPLETE FRONT END PROTECTION PACKAGE

VEHICLE SPECIFIC CONTOUR DESIGN PROVIDES THE BEST OVERALL LOOK AND FIT

PUSH BUMPER ELITE
REQUIRED (SOLD SEPARATELY)

1-1/2" DIAMETER
STEEL TUBE

BOLTS TO PUSH BUMPER ELITE
OR ELITE XD WITH 7 GAUGE
ATTACHMENT PLATE

VERTICAL 1-1/2" DIAMETER SUPPORT
BAR ABSORBS THE IMPACT IN THE
EVENT OF A COLLISION

BOLTS DIRECTLY TO PIT BAR
(ON MOST APPLICATIONS)

PATENTED PIT BAR ELITE
(SOLD SEPARATELY)

SPECIFICATIONS:

FINISH: E-COATED / BLACK POWDER COAT

MATERIAL: 14 GAUGE HRPO STEEL

VISIBLE HARDWARE: BLACK PLATED STAINLESS STEEL

WARRANTY: 3 YEAR

#WESTINPUBLICSAFETY

24

PRODUCT CATALOG

START	END	MAKE	MODEL	PUSH BUMPER ELITE	PIT BAR	WING WRAP ELITE*
2021	2021	CHEVY	TAHOE PPV	36-4045	36-4045PB	36-4045W
2020	2021	FORD	POLICE INTERCEPTOR UTILITY ²	36-2125	36-2125PB	36-2125W
2016	2019	FORD	POLICE INTERCEPTOR UTILITY ²	36-2055	36-2055PB	36-2055W
2012	2015	FORD	POLICE INTERCEPTOR UTILITY ²	36-2005	36-2005PB	36-2005W
2013	2019	FORD	POLICE INTERCEPTOR SEDAN ^{1, 2}	36-2015	36-2015PB	36-2015W
2011	2021	DODGE	CHARGER PURSUIT ²	36-2035	36-2035PB	36-2035W

*PUSH BUMPER ELITE AND PIT BAR REQUIRED. SOLD SEPARATELY.

START	END	MAKE	MODEL	PUSH BUMPER ELITE XD	PIT BAR	WING WRAP ELITE*
2019	2019	CHEVY	SILVERADO LD ^{1, 2}	36-53875	N/A	36-53875W
2016	2018	CHEVY	SILVERADO 1500 ^{1, 2}	36-53875	N/A	36-53875W
2014	2015	CHEVY	SILVERADO 1500 ^{7, 9}	36-53685	N/A	36-53685W
2015	2020	CHEVY	TAHOE PPV	36-53805	36-53805PB	36-53805W
2018	2020	FORD	F-150 SSV/POLICE RESPONDER ^{3, 7, 8}	36-52065	36-52065PB	36-52065W
2019	2020	RAM	RAM SSV 1500 CLASSIC ^{4, 7, 8}	36-53545	N/A	36-53545W
2013	2018	RAM	RAM SSV 1500 ^{4, 7, 8}	36-53545	N/A	36-53545W
2019	2021	CHEVY	SILVERADO 1500 (EXCL. LD 2019) ^{1, 4, 5, 6}	36-53955	N/A	36-53955W

**PUSH BUMPER ELITEXD REQUIRED. SOLD SEPARATELY.

FOOTNOTES: 1. TRIMMING IS REQUIRED OF TOW HOOK PLASTIC POCKETS 2. TOW HOOKS CANNOT BE REUSED WITH WINCH TRAY APPLICATIONS 3. PIT BAR ONLY FITS 2018-2019 XL / RESPONDER 4. WILL INTERFERE WITH FRONT PARKING SENSORS 5. WILL INTERFERE WITH FUNCTION OF FRONT CAMERA IF EQUIPPED 6. WILL INTERFERE WITH BLOCK HEATER PLUG 7. WILL INTERFERE WITH "ADAPTIVE CRUISE CONTROL", OR FORWARD COLLISION WARNING SYSTEMS THAT FEATURE GRILLE MOUNTED LASER CONTROL SENSORS IF EQUIPPED. 8. REMOVAL OF TOW HOOKS REQUIRED FOR INSTALLATION IF EQUIPPED. 9. TRIMMING OF AIR DAM / LOWER BUMPER VALANCE REQUIRED.



THE ELITE WING WRAPS PROVIDE ADDED FRONT-END AND HEADLIGHT PROTECTION. THEY CONNECT TO THE PRE-DRILLED PUSH BUMPER AND PIT BAR INTO A ONE-PIECE ASSEMBLY. THEY FEATURE WELDED CROSS BARS (VARIES BY APPLICATION) AND ATTACH TO THE PUSH BUMPER WITH A 7 GAUGE PLATE. THEY ARE ALSO EQUIPPED WITH A 1-1/2" DIAMETER VERTICAL SUPPORT BAR TO ABSORB IMPACT IN THE EVENT OF A COLLISION.

36-2055W / INTERCEPTOR UTILITY

36-52065W / FORD F-150

36-53685W / CHEVY SILVERADO



SHOWN WITH PUSH BUMPER ELITE AND PIT BAR ELITE



SHOWN WITH PUSH BUMPER ELITE XD AND PIT BAR ELITE



SHOWN WITH PUSH BUMPER ELITE XD

CALL 800.345.8476 OR VISIT



WESTINPUBLICSAFETY.COM

KODAK SAFETY FILM



WESTIN
PUBLIC SAFETY DIVISION

HDX BANDIT FRONT AND REAR BUMPERS

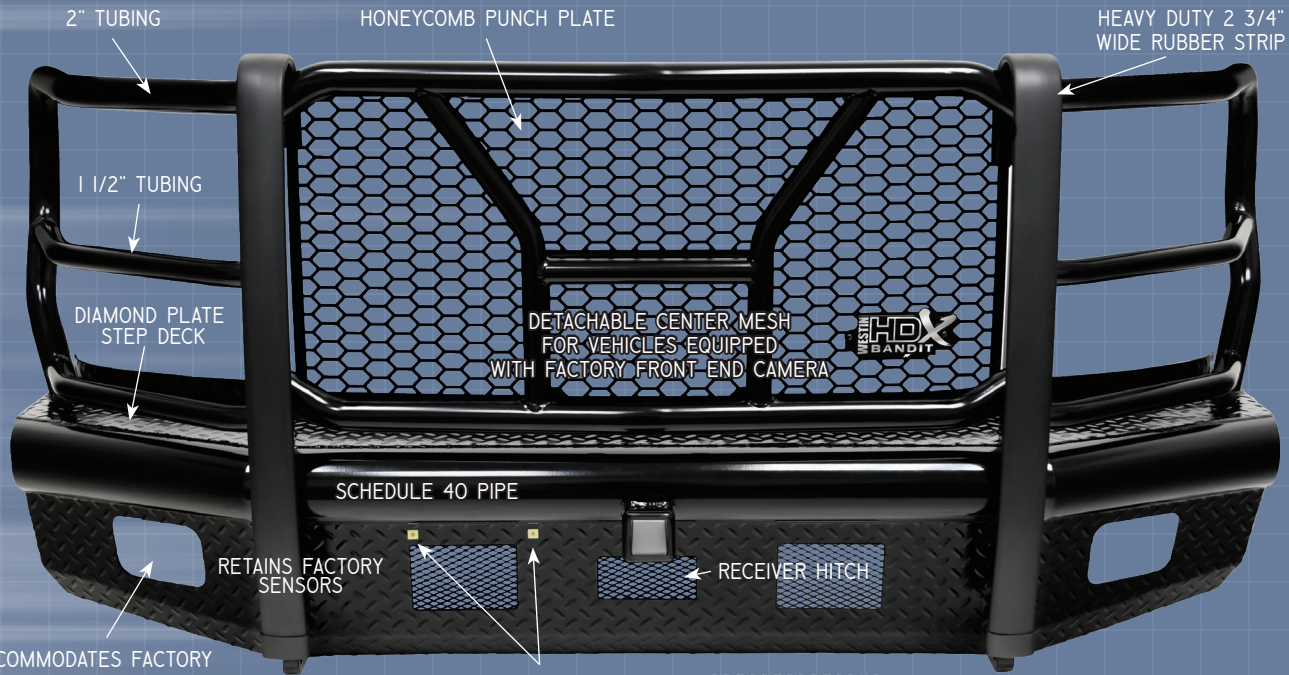

ACCOMMODATES FACTORY FOG LIGHTS OR WESTIN HYPERQ LED LIGHTS

LICENSE PLATE MOUNT POINTS

SPECIFICATIONS:
FINISH: BLACK POWDER COAT
MATERIAL: E-COATED STEEL
WARRANTY: 3 YEAR

START	END	MAKE	MODEL	FRONT
2019	2021	CHEVY	SILVERADO 1500 (EXCL. 2019 SILVERADO LD) ^{1, 6, 7}	58-31135
2011	2014	CHEVY	SILVERADO 2500/3500 ¹	58-31145
2015	2019	CHEVY	SILVERADO 2500/3500 ¹	58-31155
2020	2021	CHEVY	SILVERADO 2500/3500 ^{4, 2}	58-31185
2018	2020	FORD	F-150 SSV/POLICE RESPONDER (EXCL. ECOBOOST) ¹	58-31105
2011	2016	FORD	F-250/350 ¹	58-31115
2017	2019	FORD	F-250/350 ^{1, 2}	58-31125
2010	2018	RAM	2500/3500 ^{1, 3}	58-31175
2019	2021	RAM	2500/3500 ^{4, 2}	58-31185

FOOTNOTES: 1. FACTORY TOW HOOKS CANNOT BE RE-USED 2. OPTIONAL FRONT FACING CAMERA WILL BE PARTIALLY BLOCKED 3. EXCLUDES POWER WAGON 4. OEM TOW HOOKS NOT COMPATIBLE 6. SENSOR KIT REQUIRED TO RE-USE SENSOR 7. EXCLUDES VEHICLES W/ FRONT PARKING SENSORS



START	END	MAKE	MODEL	REAR
2011	2014	CHEVY	SILVERADO 2500/3500	58-341145
2015	2019	CHEVY	SILVERADO 2500/3500	58-341155
2019	2021	CHEVY	SILVERADO 1500 (EXCL. 2019 LD)	58-341185
2020	2021	CHEVY	SILVERADO 2500/3500 ²	58-341185
2015	2020	FORD	F-150 SSV/POLICE RESPONDER ¹	58-341105
2011	2016	FORD	F-250/350	58-341115
2017	2021	FORD	F-250/350 ¹	58-341125
2019	2021	RAM	2500/3500	58-341195
2009	2018	RAM	RAM 1500	58-341175
2019	2020	RAM	1500 CLASSIC	58-341175
2010	2021	RAM	2500/3500 (EXCL. DUAL EXHAUST)	58-341175
2019	2021	GMC	SIERRA 1500 (EXCL. 2019 LIMITED)	58-341185

FOOTNOTES: 1. MINOR GRINDING OF OEM HITCH REQUIRED 2. NOT COMPATIBLE WITH DUAL EXHAUST MODELS



KODAK SAFETY FILM



THE HDX BANDIT BUMPER COMBINES A HEAVY DUTY DIAMOND PLATE STEEL BUMPER, SCHEDULE 40 STEEL PIPE AND A STYLISH GRILLE GUARD. PROTECTS HEADLIGHTS, GRILLE, HOOD AND FRONT FENDERS FROM ROAD HAZARDS, DEBRIS AND WILDLIFE. A STYLISH METAL HONEYCOMB MESH SCREEN ALLOWS MAXIMUM AIRFLOW WITH A CLEAN AND RUGGED LOOK. INCLUDES A BUILT-IN 2" RECEIVER HITCH AND (2) HEAVY DUTY 9,500 LBS BOW SHACKLE MOUNTS. BOLT-ON INSTALLATION WITH COMPLETE HARDWARE AND BRACKETS. AVAILABLE IN BLACK POWDER COAT FINISH.



2020 CHEVY 2500



2019 RAM 2500



2019 FORD SUPERDUTY

CALL 800.345.8476 OR VISIT WESTINPUBLICSAFETY.COM



WESTIN
PUBLIC SAFETY DIVISION

HDX WINCH MOUNT GRILLE GUARD

MAXIMUM STRENGTH

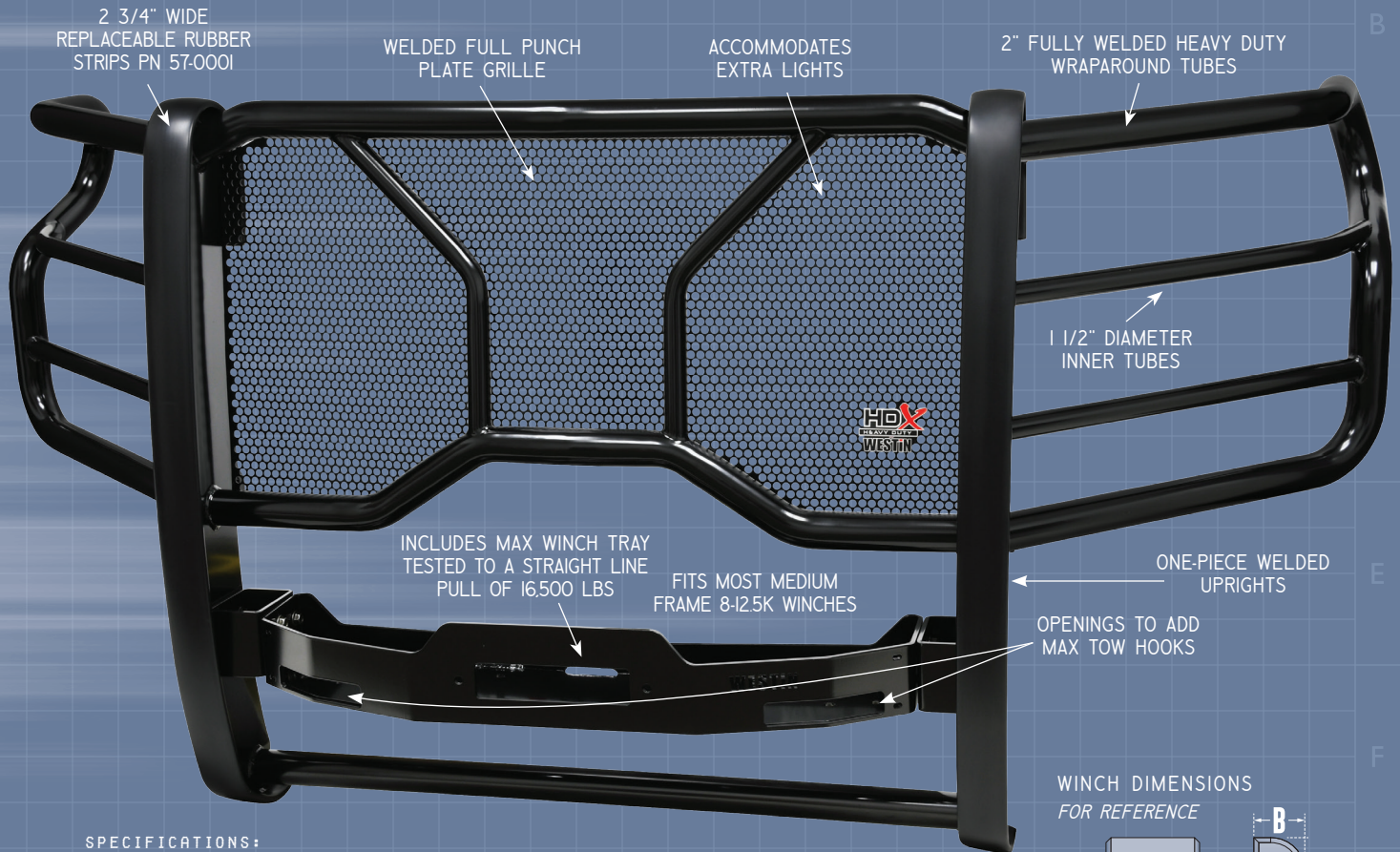

SPECIFICATIONS:

FINISH: E-COATED / BLACK POWDER COAT
 MATERIAL: HRPO STEEL
 VISIBLE HARDWARE: BLACK PLATED STAINLESS STEEL
 WARRANTY: 3 YEAR

WINCH DIMENSIONS FOR REFERENCE

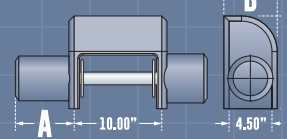

START	END	MAKE	MODEL	HDX WINCH MOUNT GG	MAX WINCH DIMS	
					A	B
2019	2019	CHEVY	SILVERADO LD ^{9, 10, 11, 12, 22}	57-93875	6.5"	6.75"
2016	2018	CHEVY	SILVERADO 1500 ^{9, 10, 11, 12, 22}	57-93875	6.5"	6.75"
2014	2015	CHEVY	SILVERADO 1500 ^{8, 9, 10, 11}	57-93685	6.5"	6.75"
2007	2013	CHEVY	SILVERADO 1500 (EXCL. CLASSIC) ^{1, 5, 9}	57-92275	6.5"	6.75"
2019	2021	CHEVY	SILVERADO 1500 (EXCL. 2019 SILVERADO LD) ^{9, 10, 11, 12, 21}	57-93955	-	-
2011	2014	CHEVY	SILVERADO 2500/3500HD ^{1, 8, 9}	57-93615	6.5"	6.75"
2015	2019	CHEVY	SILVERADO 2500/3500HD ^{9, 11}	57-93785	6.5"	6.75"
2020	2021	CHEVY	SILVERADO 2500/3500 ^{9, 10, 11, 12, 14}	57-93995	-	-
2015	2020	CHEVY	SUBURBAN/TAHOE ^{9, 10, 11, 14, 15, 17, 19}	57-93805	6.5"	6.75"
2021	2021	CHEVY	SUBURBAN/TAHOE	57-94045	-	-
2019	2020	DODGE/RAM	RAM 1500 CLASSIC ^{7, 8, 9, 16}	57-93545	6.6"	6.4"
2009	2018	DODGE/RAM	RAM 1500 ^{7, 8, 9, 16}	57-93545	6.6"	6.4"
2010	2018	DODGE/RAM	RAM 2500/3500 ^{1, 8, 9}	57-93555	6.5"	6.75"
2011	2016	FORD	F-250/350 SUPER DUTY ^{8, 9}	57-92375	6.5"	7.0"
2017	2019	FORD	F-250/350 SUPER DUTY (EXCL. HARLEY DAVIDSON EDTN) ^{1, 9, 10, 12, 14}	57-93905	7.0"	6.5"
2020	2021	FORD	F-250/350	57-94015	-	-
2015	2020	FORD	F-150 SSV/POLICE RESPONDER ^{1, 8, 9, 10, 12, 13, 14}	57-93835	7.0"	6.5"
2009	2014	FORD	F-150 SSV/POLICE RESPONDER ^{1, 2, 8, 9, 13}	57-92505	7.0"	6.5"
2019	2021	FORD	RANGER ^{8, 9, 10, 11, 20, 23}	57-93985	-	-
2019	2021	RAM	1500 (EXCL. 2019 RAM 1500 CLASSIC)(EXCL REBEL) ^{7, 8, 9}	57-93975	-	-
2019	2021	RAM	2500/3500 ^{9, 10, 12, 22, 24}	57-94025	-	-
2014	2021	TOYOTA	TUNDRA ^{1, 8, 18}	57-93705	7.0"	6.5"

SET OF 2 LIGHT CLAMPS SOLD SEPARATELY: PN 57-0000 (STAINLESS) AND 57-0005 (BLACK). DRILLING MAY BE REQUIRED FOR SOME APPLICATIONS

FOOTNOTES: 1. REQUIRES LOWER BUMPER GRILLE TRIMMING FOR INSTALL ON 2010-14 MODELS 2. TRIMMING OF SECOND AIR DAM REQUIRED 5. DRILLING REQUIRED 6. MINOR TRIMMING REQUIRED ON 2010 - 2013 MODELS 7. REMOVAL OR TRIMMING OF PLASTIC BUMPER INSERT REQUIRED ON VEHICLES THAT DID NOT COME WITH FACTORY TOW HOOKS 8. WILL INTERFERE WITH ADAPTIVE CRUISE CONTROL OR FORWARD COLLISION WARNING SYSTEMS 9. FACTORY TOW HOOKS CANNOT BE RE-USED 10. MINOR TRIMMING OF TOW HOOK POCKETS REQUIRED 11. WILL INTERFERE WITH FRONT PARKING SENSORS IF EQUIPPED 12. WILL INTERFERE WITH FRONT CAMERA IF EQUIPPED 13. WILL PARTIALLY BLOCK AIRFLOW TO INTERCOOLER ON ECOBOOST MODELS 14. WILL INTERFERE WITH ADAPTIVE CRUISE CONTROL IF EQUIPPED 15. TRIMMING TO FRONT BUMPER PLASTIC REQUIRED 16. EXCLUDES REBEL MODEL 17. EXCLUDE MODELS WITH "LANE DEPARTURE DISTANCE MODULE" 18. WILL INTERFERE WITH THE FUNCTION OF THE TOYOTA SAFETY SENSE (TSS) SYSTEM ON 2018 AND UP MODELS 19. SKIDPLATE MUST BE REMOVED ON Z71 MODELS 20. TRIMMING OF CENTER PANEL OF BUMPER 21. WILL INTERFERE WITH BLOCK HEATER PLUG 22. WILL INTERFERE WITH FRONT PARKING SENSORS (IF EQUIPPED) 23. EXCLUDES MODELS WITH SKID PLATE 24. LICENSE RELOCATOR NEEDED FOR LICENSE PLATE TO BE VISIBLE



WESTIN'S HDX WINCH MOUNT GRILLE GUARD ATTACHES DIRECTLY TO THE VEHICLE'S FRAME FOR MAXIMUM STRENGTH. THE HEAVY DUTY DESIGN IS IDEAL FOR THE NEEDS OF TODAY'S PUBLIC SAFETY OFFICER. IT FEATURES WELDED UPRIGHTS, 2" WRAPAROUND TUBES AND A FULL PUNCH PLATE GRILLE THAT ALLOW EMERGENCY LIGHTS TO BE MOUNTED. THE MAX WINCH TRAY IS PRE-DRILLED TO ACCOMMODATE MOST MEDIUM FRAME WINCHES.

OTHER ACCESSORIES AVAILABLE:

**SUPERWINCH TALON
9.5ISR WINCH**



PART NO. 1695211

MAX[®] TOW HOOK



PART NO. 46-3005
1 UNIT PER PACKAGE

**HDX B-FORCE FLUSH
MOUNT LED KIT**



6" KIT PART NO. 57-0025
10" KIT PART NO. 57-0035

CALL 800.345.8476 OR VISIT



WESTINPUBLICSAFETY.COM



TALON SERIES

TALON 9.5

PN# 1695200

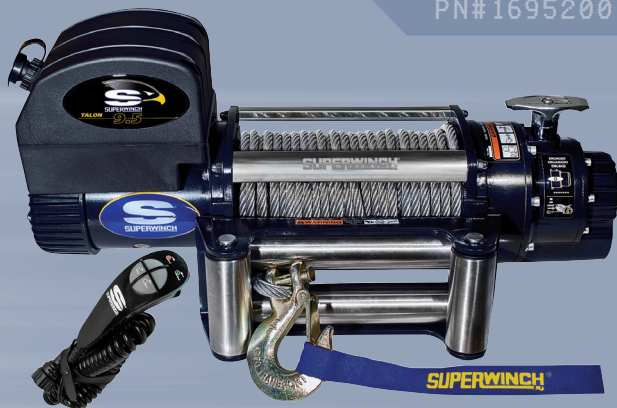

TALON 9.5 SR

PN# 1695201



TALON 9.5i

PN# 1695210



TALON 9.5iSR

PN# 1695211



NO ONE LIKES WAITING ON A SLOW WINCH; THE SUPERWINCH TALON SERIES COMBINES SUPER FAST LINE SPEED DURING CABLE RETRIEVAL, WITH OUTSTANDING PULLING POWER AND STOUT 2-STAGE PLANETARY GEARS FOR STEADY AND PREDICTABLE OPERATION. THE INNOVATIVE EXTERNAL DISC BRAKE DESIGN PROVIDES 100% LOAD HOLD WHEN RUNNING THE BRAKE HARD. TALON ALSO FEATURES EASY OPERATION "PULL AND TURN" CLUTCH ENGAGEMENT. TALON HAS IT ALL SPEED, POWER AND DURABLE PERFORMANCE.



TALON MODEL	ROPE TYPE	ROPE SIZE (D" X L')	RATED PULL (LBS)	HP	FAIR LEAD ¹	GEAR RATIO ²	FPM NO/LD	FPM LOAD	AMPS NO/LD	AMPS LOAD	WT LBS	PART NO.
9.5	WIRE	3/8 X 85	9,500	5.2	ROLLER	148:1	62	5	75	430	90	1695200
9.5SR	SYN	3/8 X 80	9,500	5.2	HAWSE	148:1	62	5	75	430	66	1695201
9.5i	WIRE	3/8 X 85	9,500	5.2	ROLLER	148:1	62	5	80	410	92	1695210
9.5iSR	SYN	3/8 X 85	9,500	5.2	HAWSE	148:1	62	5	80	410	67	1695211

TIGER SHARK



TS 9500

PN# 1595200



TS 9500 SR

PN# 1595201



TS 11500

PN# 1511200



TS 11500 SR

PN# 1511201



ONE OF SUPERWINCH'S MOST POPULAR WINCHES, THE TIGER SHARK IS THE BENCHMARK FOR PERFORMANCE WINCHING WHILE NOT BREAKING THE BANK. FROM POWERFUL MOTORS, TO STRONG GEARS, TO LONG-LIFE STAINLESS STEEL PARTS, THE TIGER SHARK 9500 STANDS OUT FROM THE COMPETITION. IT IS EASY TO SEE WHY THE TIGER SHARK REMAINS ONE OF SUPERWINCH'S MOST POPULAR WINCHES YEAR AFTER YEAR.



TIGER SHARK	ROPE TYPE	ROPE SIZE (D' X L')	RATED PULL (LBS)	HP	FAIR LEAD ¹	GEAR RATIO ²	FPM NO/LD	FPM LOAD	AMPS NO/LD	AMPS LOAD	WT LBS	PART NO.
9500	WIRE	²¹ / ₆₄ X 95	9,500	5.2	ROLLER	218:1	19	4	80	340	90	1595200
9500 SR	SYN	³ / ₈ X 80	9,500	5.2	HAWSE	218:1	19	4	80	340	59	1595201
11500	WIRE	³ / ₈ X 84	11,500	6	ROLLER	218:1	19	2	80	410	94	1511200
11500 SR	SYN	³ / ₈ X 80	11,500	6	HAWSE	218:1	19	2	80	410	59	1511201

CALL 800.345.8476 OR VISIT  WESTINPUBLICSAFETY.COM



TERRA SERIES

TERRA 25



PN#1125220

TERRA 25SR

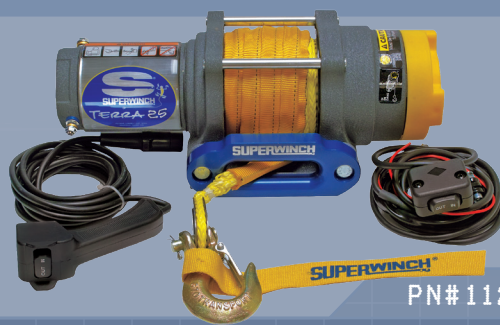

PN#1125230

TERRA 35



PN#1135220

TERRA 35SR



PN#1135230

TERRA 45



PN#1145220

TERRA 45SR



PN#1145230

THE SUPERWINCH TERRA SERIES IS THE STANDOUT PERFORMER IN POWERSPORTS ATV/UTV WINCHING. IT'S NOT A CLAIM WE MAKE LIGHTLY AND WE BACK IT UP WITH STRONGER MOTORS, WIDER GEARS, BEEFED UP DRUMS AND DURABLE STEEL CABLE. DESIGNED WITH THE TOUGHEST TERRAINS IN MIND, THIS SERIES OF ATV AND SIDE BY SIDE WINCHES, DELIVERS PULL RATINGS OF 2,500-4,500 LBS FEATURES RUGGED ALL METAL 3-STAGE PLANETARY GEAR TRAIN CONSTRUCTION.



TERRA MODEL	ROPE TYPE	ROPE SIZE (D' X L')	RATED PULL (LBS)	HP	FAIR LEAD ¹	GEAR RATIO ²	FPM NO/LD	FPM LOAD	AMPS NO/LD	AMPS LOAD	WT LBS	PART NO.
25	WIRE	3/16 X 50	2,500	1.3	ROLLER	140:1	26	10.5	25	162	18	1695200
25SR	SYN	3/16 X 50	2,500	1.3	HAWSE	140:1	26	10.5	25	162	15	1695201
35	WIRE	7/32 X 50	3,500	1.6	ROLLER	140:1	24	10	19	190	20	1695210
35SR	SYN	3/16 X 50	3,500	1.6	HAWSE	140:1	24	10	19	190	17	1695211
45	WIRE	1/4 X 55	4,500	1.6	ROLLER	191:1	15	4.5	75	190	22	1612200
45SR	SYN	1/4 X 55	4,500	1.6	HAWSE	191:1	15	4.5	75	190	19	1612201

WINCH2GO



WINCH2GO

- RATED LINE PULL OF 4,000 LBS
- 1.4 HP PERMANENT MAGNET MOTOR
- CAM ACTION KNOB FREESPOOL CLUTCH
- WIRE ROPE MEASURES 7/32" X 40'
- SEALED HANDHELD WIRED REMOTE
- STEEL BASE PLATE WITH INTEGRATED HAWSE
- 1/4" CLEVIS PINNED, LATCHED HOOK
- 12' HANDHELD REMOTE CONTROL
- (2) HEAVY DUTY 8' STRAPS RATED AT 4,000 LBS
- (3) 4,000 LBS D-SHACKLES
- 8,000 LBS SNATCH BLOCK
- 10' QUICK CONNECT BATTERY CABLES
- PAIR OF HEAVY DUTY WINCH GLOVES
- WEIGHS 43 LBS



PN#1140222

WINCH2GO SR

- RATED LINE PULL OF 4,000 LBS
- 1.4 HP PERMANENT MAGNET MOTOR
- CAM ACTION KNOB FREESPOOL CLUTCH
- SYNTHETIC ROPE MEASURES 7/32" X 40'
- SEALED HANDHELD WIRED REMOTE
- STEEL BASE PLATE WITH INTEGRATED HAWSE
- 1/4" CLEVIS PINNED, LATCHED HOOK
- 12' HANDHELD REMOTE CONTROL
- (2) HEAVY DUTY 8' STRAPS RATED AT 4,000 LBS
- (3) 4,000 LBS D-SHACKLES
- 8 8,000 LBS SNATCH BLOCK
- 10' QUICK CONNECT BATTERY CABLES
- PAIR OF HEAVY DUTY WINCH GLOVES
- WEIGHS 41 LBS



PN#1140232

THIS "WINCH IN A BOX" OFFERS A VARIETY OF USES FOR HOME, WORK, ROAD OR PLAY. WINCH2GO COMES COMPLETE WITH ALL THE GEAR AND ACCESSORIES YOU NEED FROM SNATCH BLOCK, STRAPS, SHACKLES AND EVEN A PAIR OF WINCH GLOVES. NEVER GET STRANDED AGAIN, REGARDLESS OF WEATHER OR TERRAIN WINCH2GO ONLY NEEDS A BASIC ANCHOR POINT FOR RECOVERY, IF THERE IS A ROCK, OR TREE, OR VEHICLE TO TIE TO, WINCH2GO CAN DO THE REST. FEATURES A QUICK CONNECT POWER CORD AND AN 8,000 LBS SNATCH BLOCK.



WINCH	ROPE TYPE	ROPE SIZE (D' X L')	RATED PULL (LBS)	HP	FAIR LEAD ¹	GEAR RATIO ²	FPM NO/LD	FPM LOAD	AMPS NO/LD	AMPS LOAD	WT LBS	PART NO.
W2G	WIRE	7/32 X 40	4,000	1.4	ROLLER	166:1	20	5.5	20	220	43	1140222
W2GSR	SYN	7/32 X 40	4,000	1.4	HAWSE	166:1	20	5.5	20	220	41	1140232

FOOTNOTES: 1. ROLLER: STAINLESS STEEL 4-WAY ROLLER / HAWSE: BLUE ANODIZED ALUMINUM 2. 2-STAGE SPUR / 2-STAGE PLANETARY 3. 2-STAGE SPUR / 2-STAGE PLANETARY



WESTIN
PUBLIC SAFETY DIVISION

LED LIGHTING

B-FORCE

BLACK FACE DIAMOND PLATE PATTERN
DOUBLE OR SINGLE ROW

- 6063 EXTRUDED ALUMINUM HOUSING WITH DIE-CAST ENDS
- DUST AND MOISTURE RESISTANT LENS
- INCLUDES MOUNTING HARDWARE AND PIGTAIL CONNECTOR
- LIMITED LIFETIME WARRANTY
- REGISTERED U.S. PATENT



PIGTAIL CONNECTORS



FLOOD BEAM

COMBO BEAM

HDX B-FORCE

FLUSH MOUNT LED KIT

- INCLUDES: (2) B-FORCE DOUBLE ROW LIGHT BARS, (2) FACEPLATES, (2) ADJUSTABLE SLIDER BRACKETS, WIRING HARNESS AND MOUNTING HARDWARE
- DIRECT BOLT-ON OR PUNCH PLATE INSTALLATION
- REGISTERED U.S. PATENT



WIRING HARNESS INCLUDED



COMBO BEAM

HYPERQ B-FORCE

BLACK FACE DIAMOND PLATE PATTERN
LED AUXILIARY LIGHTS

- BLACK DIAMOND PLATE FACEPLATES
- BLACK PLATED STAINLESS HARDWARE
- DUST AND MOISTURE RESISTANT LENS
- LIMITED LIFETIME WARRANTY
- AVAILABLE IN PAIR PACK ONLY
- AVAILABLE IN SPOT AND FLOOD BEAM



WIRING HARNESS INCLUDED



FLOOD BEAM

SPOT BEAM

HYPERQ

LED AUXILIARY LIGHTS

- 5W LED CHIPS
- DUST AND MOISTURE RESISTANT LENS
- LIMITED LIFETIME WARRANTY
- AVAILABLE IN PAIR PACK ONLY
- AVAILABLE IN SPOT AND FLOOD BEAM



WIRING HARNESS INCLUDED



FLOOD BEAM

SPOT BEAM

LED LIGHTING



WESTIN
PUBLIC SAFETY DIVISION

AXIS

LED AUXILIARY LIGHTS

- DUST & MOISTURE RESISTANT LENS
- DIE-CAST ALUMINUM HOUSING
- PIVOTING BASE MOUNT BRACKET
- INCLUDES MOUNTING HARDWARE & PIGTAIL CONNECTOR
- LIMITED LIFETIME WARRANTY
- AVAILABLE IN PAIR PACK ONLY
- AVAILABLE IN FLOOD OR SPOT BEAM



PIGTAIL CONNECTORS

FLOOD BEAM

SPOT BEAM

WORK UTILITY LIGHTS

AVAILABLE ROUND OR SQUARE SPOT OR FLOOD

- DUST & MOISTURE RESISTANT LENS
- PIVOTING BASE MOUNT BRACKET
- INCLUDES MOUNTING HARDWARE AND PIGTAIL CONNECTOR
- LIMITED LIFETIME WARRANTY
- AVAILABLE IN FLOOD OR SPOT BEAM

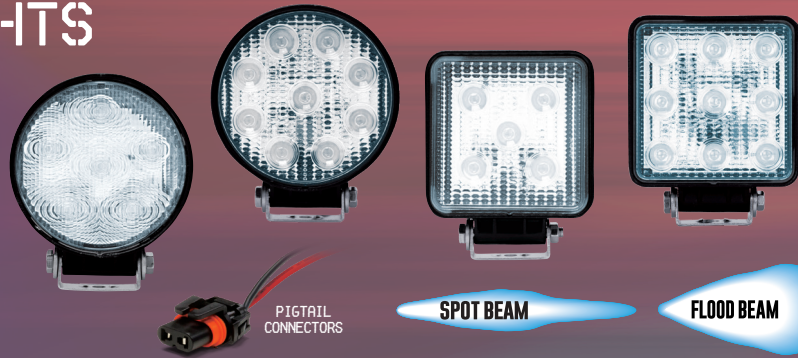

SPOT BEAM

FLOOD BEAM

DESCRIPTION	OUTPUT	BEAM	LEDS	SIZE	LUMENS	PART NO.
B-FORCE DOUBLE ROW	12W	FLOOD	4 X 3W	2"	1000	09-12212-4F
B-FORCE DOUBLE ROW	24W	FLOOD	8 X 3W	4"	2160	09-12212-8F
B-FORCE DOUBLE ROW	36W	COMBO	12 X 3W	6"	3240	09-12212-12C
B-FORCE DOUBLE ROW	60W	COMBO	20 X 3W	10"	5400	09-12212-20C
B-FORCE DOUBLE ROW	72W	COMBO	24 X 3W	12"	6480	09-12212-24C
B-FORCE DOUBLE ROW	120W	COMBO	40 X 3W	20"	10800	09-12212-40C
B-FORCE DOUBLE ROW	180W	COMBO	60 X 3W	30"	16200	09-12212-60C
B-FORCE DOUBLE ROW	240W	COMBO	80 X 3W	40"	21600	09-12212-80C
B-FORCE DOUBLE ROW	300W	COMBO	100 X 3W	50"	27000	09-12212-100C
B-FORCE SINGLE ROW	30W	FLOOD	6 X 5W	6"	2980	09-12211-6F
B-FORCE SINGLE ROW	50W	COMBO	10 X 5W	10"	4980	09-12211-10C
B-FORCE SINGLE ROW	100W	COMBO	20 X 5W	20"	9960	09-12211-20C
B-FORCE SINGLE ROW	150W	COMBO	30 X 5W	30"	14940	09-12211-30C
B-FORCE SINGLE ROW	200W	COMBO	40 X 5W	40"	19920	09-12211-40C
B-FORCE SINGLE ROW	250W	COMBO	50 X 5W	50"	24900	09-12211-50C
HDX FLUSH MOUNT KIT 6"	36W	COMBO	12 X 3W	6"	3240	57-0025
HDX FLUSH MOUNT KIT 10"	60W	COMBO	20 X 3W	10"	5400	57-0035
HYPER Q B-FORCE, SPOT	20W	SPOT	4 X 5 CREE	3.2" X 3.0"	1080	09-12205A-PR
HYPER Q B-FORCE, FLOOD	20W	FLOOD	4 X 5 CREE	3.2" X 3.0"	1080	09-12205B-PR
HYPER Q, SPOT	20W	SPOT	4 X 5W CREE	3.2" X 3.0"	1080	09-12200A-PR
HYPER Q, FLOOD	20W	FLOOD	4 X 5W CREE	3.2" X 3.0"	1080	09-12200B-PR
AXIS ROUND, SPOT	27W	SPOT	9 X 3W	4.7"	2025	09-12007A-PR
AXIS ROUND, FLOOD	27W	FLOOD	9 X 3W	4.7"	2025	09-12007B-PR
AXIS SQUARE, SPOT	27W	SPOT	9 X 3W	4.6" X 4.6"	2025	09-12219A-PR
AXIS SQUARE, FLOOD	27W	FLOOD	9 X 3W	4.6" X 4.6"	2025	09-12219B-PR
ROUND 6 LED, SPOT	18W	SPOT	6 X 3W	4.6"	950	09-12005A
ROUND 6 LED, FLOOD	18W	FLOOD	6 X 3W	4.6"	950	09-12005B
ROUND 9 LED, SPOT	27W	SPOT	9 X 3W	4.9" X 5.4"	1450	09-12006A
ROUND 9 LED, FLOOD	27W	FLOOD	9 X 3W	4.9" X 5.4"	1450	09-12006B
SQUARE 5, SPOT	15W	SPOT	5 X 3W	4.3" X 5.0"	800	09-12210A
SQUARE 5, FLOOD	15W	FLOOD	5 X 3W	4.3" X 5.0"	800	09-12210B
SQUARE 9, SPOT	27W	SPOT	9 X 3W	4.6" X 5.3"	1450	09-12211A
SQUARE 9, FLOOD	27W	FLOOD	9 X 3W	4.6" X 5.3"	1450	09-12211B

LED ACCESSORIES/HARNESSES	QUAN.	SIZE	PART NO.
HDX LIGHT CLAMPS, STAINLESS	2	UNI	57-0000
HDX LIGHT CLAMPS, BLACK	2	UNI	57-0005
HDX GRILLE GUARD LED LIGHT BRACKETS FOR 20" OR 30" LED BAR, STAINLESS	2	UNI	57-0010
HDX GRILLE GUARD LED LIGHT BRACKETS FOR 20" OR 30" LED BAR, BLACK	2	UNI	57-0015
14 GAUGE HARNESSES/INCLUDES 15A FUSE, WIRE LOOM COVER, (1) CONNECTOR	1	11'	09-12000-1
12 GAUGE HARNESSES/INCLUDES 30A FUSE, WIRE LOOM COVER, (1) CONNECTOR	1	11'	09-12000-5
14 GAUGE HARNESSES/INCLUDES 20A FUSE, WIRE LOOM COVER, (2) CONNECTORS	1	14'	09-12000-8

CALL 800.345.8476 OR VISIT

35

WESTINPUBLICSAFETY.COM



WESTIN
PUBLIC SAFETY DIVISION

HLR TRUCK RACK

STRONG, STURDY, LIGHTWEIGHT DESIGN / EXTRUDED ALUMINUM FRAME

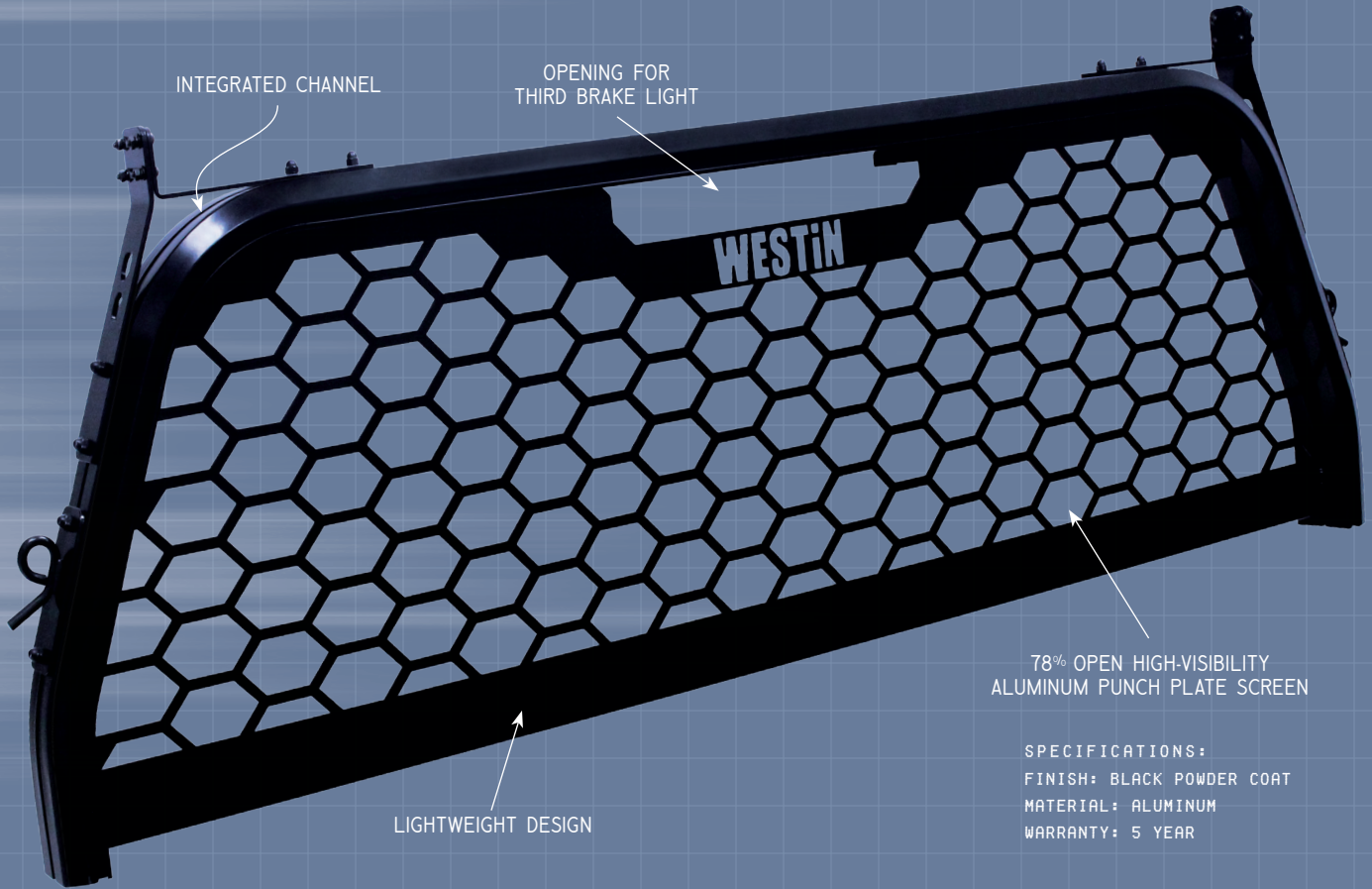

SPECIFICATIONS:
FINISH: BLACK POWDER COAT
MATERIAL: ALUMINUM
WARRANTY: 5 YEAR

START	END	MAKE	MODEL	PART NO.
2007	2018	CHEVY	SILVERADO 1500 (EXCL CLASSIC)	57-81005
2019	2021	CHEVY	SILVERADO 1500 ¹	57-81095
2007	2019	CHEVY	SILVERADO 2500/3500 (EXCL CLASSIC)	57-81005
2020	2021	CHEVY	SILVERADO 2500/3500 ¹	57-81135
2019	2019	CHEVY	SILVERADO LD	57-81005
2019	2021	DODGE	RAM 1500 (EXCL. 2019-2020 RAM 1500 CLASSIC) ²	57-81085
2009	2018	DODGE	RAM 1500 ²	57-81025
2019	2020	DODGE	RAM 1500 CLASSIC ²	57-81025
2010	2018	DODGE	RAM 2500/3500 ²	57-81025
2015	2020	FORD	F150	57-81035
1999	2016	FORD	F250/350/450/550 SUPER DUTY	57-81045
2017	2021	FORD	F250/350/450/550 SUPER DUTY	57-81055
2007	2018	GMC	SIERRA 1500 (EXCL CLASSIC)	57-81005
2019	2021	GMC	SIERRA 1500 ¹	57-81095
2019	2019	GMC	SIERRA 1500 LIMITED	57-81005
2007	2019	GMC	SIERRA 2500/3500 (EXCL CLASSIC)	57-81005
2020	2021	GMC	SIERRA 2500/3500 ¹	57-81135
2019	2021	RAM	1500 (EXCL. 2019-2020 RAM 1500 CLASSIC) ²	57-81085
2009	2018	RAM	1500 ²	57-81025
2019	2020	RAM	1500 CLASSIC ²	57-81025
2010	2018	RAM	2500/3500 ²	57-81025
2005	2021	TOYOTA	TACOMA	57-81065
2007	2021	TOYOTA	TUNDRA	57-81075

ACCESSORIES	PART NO.
ADJUSTABLE TIE DOWN - SINGLE POINT	57-89005
ADJUSTABLE TIE DOWN - MULTI-POINT	57-89015
LED LIGHT BAR BRACKETS	57-89035
LED AUXILIARY LIGHT MOUNT	57-89045
BEACON LIGHT MOUNT - SMALL	57-89055
BEACON LIGHT MOUNT - LARGE	57-89065
MINI LIGHT BAR MOUNTS	57-89075

FOOTNOTES: 1. MAY BLOCK CAMERA LOCATED ON THIRD BRAKE LIGHT. 2. EXCLUDE MODELS WITH RAM BOX

PROTECT YOUR REAR CABIN WINDOW WITH WESTIN'S ALL NEW HLR TRUCK RACK. THE HLR TRUCK RACK IS THE LOGICAL SOLUTION. LIGHTWEIGHT EXTRUDED ALUMINUM DESIGN COMBINES SAFETY, STYLE, VISIBILITY & DURABILITY INTO A GREAT LOOKING UPGRADE TO YOUR TRUCK. OUR UNIQUE BOLT ON CHANNEL SYSTEM UTILIZES A VARIETY OF OPTIONS TO SECURE LADDERS, LIGHTS, BEACONS & TIE-DOWNS. MOST TOOL BOXES AND CAN BE EASILY INSTALLED USING FACTORY HOLES (MOST APPLICATIONS). WEATHER RESISTANT BLACK POWDER COAT FINISH STANDS UP TO THE ELEMENTS. COMES WITH A 5-YEAR WARRANTY.



CALL 800.345.8476 OR VISIT WESTINPUBLICSAFETY.COM



WESTIN
PUBLIC SAFETY DIVISION

AGENCY TESTIMONIALS

MY 2016 CHEVROLET TAHOE IS EQUIPPED WITH A WESTIN PUSH BUMPER. IN JULY I WAS RESPONDING TO A SERIOUS MOTOR VEHICLE COLLISION THEREFORE, I WAS TRAVELING 80+ MPH WITH MY LIGHTS AND SIREN ACTIVATED. A DEER ENTERED THE ROADWAY AND I HAD NO TIME TO TAKE EVASIVE ACTION TO MISS THE DEER, NOR WOULD IT HAVE BEEN SAFE TO DO SO.

I STRUCK THE DEER WITH THE FRONT END OF MY VEHICLE. THE VEHICLE SUSTAINED MINOR DAMAGE CONSIDERING THE SPEED I WAS TRAVELING. IN FACT, WHEN IT WAS STATED I STRUCK A DEER, CO WORKERS WERE ASKING WHERE THE DAMAGE WAS BECAUSE MOST OF THE DAMAGE WAS NOT NOTICEABLE UNTIL POINTED OUT.

I FEEL YOUR PUSH BUMPER SAVED THE VEHICLE FROM TREMENDOUS DAMAGE GIVEN THE SPEED I WAS TRAVELING. IT VERY WELL MAY HAVE MADE THE DEER STRIKE SAFER FOR ME BY PREVENTING THE DEER FROM COMING UP AND OVER THE HOOD INTO THE WINDSHIELD. NUMEROUS COWORKERS ARE IN AGREEMENT THE VEHICLE'S DAMAGE WOULD HAVE BEEN MUCH, MUCH WORSE AND POSSIBLY EVEN TOTALED THE VEHICLE IF IT WEREN'T FOR THE PUSH BUMPER'S PERFORMANCE.

JASON GRAVES, CORPORAL
ST. MARY'S COUNTY SHERIFF

WE JUST INSTALLED THE FIRST WESTIN PUSH BAR ON A 2013 DODGE CHARGER. THE INSTALL WAS EASY AND SIMPLE TO DO, SO, MY TECHS ARE REALLY HAPPY ABOUT THAT. MANY THANKS FROM THEM! THE MODIFICATIONS ARE MINIMAL TO THE GRILL AND THE BUMPER. KUDOS TO THE DESIGN TEAM! THIS IS A HUGE BENEFIT WHEN IT COMES TO INSTALLATION AND LABOR COSTS. THE BUMPER SEEMS TO BE REAL STURDY, WHEN YOU TRY TO MOVE THE BUMPER IT ACTUALLY JUST MOVES THE ENTIRE VEHICLE INSTEAD OF JUST THE BUMPER. I ALSO APPRECIATE THE FACT THAT YOU WERE ABLE TO DESIGN IT USING FEDERAL

SIGNAL EQUIPMENT. IT'S IMPORTANT TO KEEP ALL OF MY LIGHTS WITH ONE MANUFACTURER SO I DONT HAVE TO STOCK A LOT OF DIFFERENT LIGHTS FOR REPAIR. MOST IMPORTANTLY IT LOOKS REALLY, REALLY COOL. IT JUST HAS A REALLY TOUGH AND INTIMIDATING LOOK TO IT. I LOOK FORWARD TO GETTING SOME PUT ON MY FORD INTERCEPTORS!

TONY GONZALEZ, MAJOR
NEW MEXICO STATE POLICE



ONE OF OUR CUSTOMERS (SASKATOON POLICE) HAS JUST STARTED PUTTING WESTIN BUMPERS ON THEIR CARS. ONE OF THEIR FORD SUVS GOT RAMMED REPEATEDLY BY THE DRIVER OF A STOLEN TRUCK THAT THEY WERE TRYING TO STOP. THEY FIGURED ABOUT \$800 DAMAGE TO THIS VEHICLE, MOSTLY BECAUSE OF THE BROKEN HEADLIGHT MODULE. MORE IMPORTANTLY, THE VEHICLE WAS NOT DISABLED SO THEY COULD CONTINUE THE CHASE AND EVENTUALLY CAUGHT THE GUY. THE STOLEN TRUCK ALSO RAMMED ANOTHER FORD UI A FEW TIMES AND THAT ONE DID NOT HAVE A WESTIN PUSHBUMPER ON IT. \$4800

DAMAGE TO THE VEHICLE, AND THE VEHICLE'S RADIATOR FAILED DUE TO THE RAMMING SO THE VEHICLE WAS OUT OF THE CHASE.

THEY WERE IMPRESSED AT HOW WELL IT STOOD UP TO THE ABUSE. THEY ARE NOW ASKING FOR PRICING FOR 30+ PUSHBUMPER ASSEMBLIES TO OUTFIT THEIR ENTIRE FLEET.

MARK YAGER, GENERAL MANAGER
SIGMA SAFETY CORPORATION



PHOTO GALLERY



WESTIN
PUBLIC SAFETY DIVISION

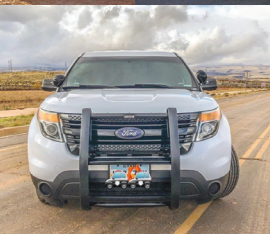
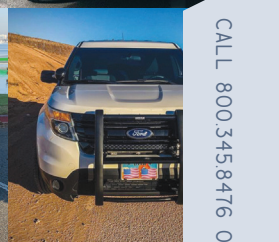

CALL 800.345.8476 OR VISIT
39 WESTINPUBLICSAFETY.COM



PROTECTING THOSE WHO PROTECT US

WESTIN PUBLIC SAFETY DIVISION

PH: 800. 345. 8476 FAX: 626. 813. 4890
320 W. COVINA BLVD. SAN DIMAS. CA 91773
E-MAIL: WESTINPSD@WESTINAUTOMOTIVE.COM

WESTIN SALES / MARKETING

PH: 626. 960. 6762 FAX: 626. 960. 2055
320 W. COVINA BLVD. SAN DIMAS. CA 91773
WWW. WESTINAUTOMOTIVE.COM

SUPERWINCH

PH: 800. 323. 2031
INFO@SUPERWINCH.COM WWW.SUPERWINCH.COM

 SEARCH #WESTINPUBLICSAFETY AND STAY CONNECTED! 
WESTINPUBLICSAFETY.COM
5.3892 | WPS13 | 090820

©2020 Westin Automotive Products, Inc. Printed in U.S.A.